

Specifications

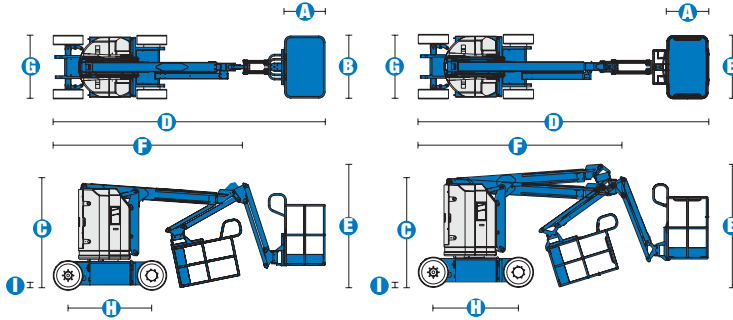

MODELS	Z™-30/20N		Z™-30/20N RJ	
MEASUREMENTS	US	Metric	US	Metric
Working height maximum*	36 ft	11.14 m	35 ft 2 in	10.89 m
Platform height maximum	30 ft	9.14 m	29 ft 2 in	8.89 m
Horizontal reach maximum	21 ft 5 in	6.53 m	20 ft 6 in	6.25 m
Up and over clearance maximum	12 ft 8 in	3.86 m	12 ft 8 in	3.86 m
A Platform length	2 ft 6 in	.76 m	2 ft 6 in	.76 m
B Platform width	3 ft 10 in	1.17 m	3 ft 10 in	1.17 m
C Height - stowed	6 ft 6.5 in	2 m	6 ft 6.5 in	2 m
D Length - stowed	16 ft 9 in	5.11 m	17 ft 5 in	5.31 m
E Storage height	6 ft 10 in	2.08 m	7 ft 4 in	2.24 m
F Storage length	11 ft 6 in	3.5 m	12 ft	3.66 m
G Width	3 ft 11 in	1.19 m	3 ft 11 in	1.19 m
H Wheelbase	5 ft 3 in	1.60 m	5 ft 3 in	1.60 m
I Ground clearance - center	3.5 in	.09 m	3.5 in	.09 m

PRODUCTIVITY	Z™-30/20N		Z™-30/20N RJ	
Lift capacity	500 lbs	227 kg	500 lbs	227 kg
Platform rotation	180°		180°	
Vertical jib rotation	139°		139°	
Horizontal jib rotation	—		180°	
Turntable rotation	355° non-continuous		355° non-continuous	
Turntable tailswing	zero		zero	
Drive speed - stowed	3.0 mph	4.8 km/h	3.0 mph	4.8 km/h
Drive speed - raised**	0.68 mph	1.1 km/h	0.68 mph	1.1 km/h
Gradeability - stowed***	35%		35%	
Turning radius - inside	5 ft 5 in	1.65 m	5 ft 5 in	1.65 m
Turning radius - outside	10 ft 7 in	3.23 m	10 ft 7 in	3.23 m
Controls	24 V DC proportional		24 V DC proportional	
Tires - solid non-marking	22x7x17.75 in	.56x.18x.45 m	22x7x17.75 in	.56x.18x.45 m

POWER	Z™-30/20N		Z™-30/20N RJ	
Power source	48 V DC (eight 6 V batteries 390 Ah capacity)		48 V DC (eight 6 V batteries 390 Ah capacity)	
Auxiliary power unit	24 V DC		24 V DC	
Hydraulic tank capacity	4 gal	15.1 L	4 gal	15.1 L

WEIGHT****	Z™-30/20N		Z™-30/20N RJ	
	14,170 lbs	6,427 kg	14,220 lbs	6,450 kg

STANDARDS COMPLIANCE ANSI A92.5, CSA B354.4, EN 280, AS 1418.10

* The metric equivalent of working height adds 2 m to platform height. U.S. adds 6 ft to platform height.
 ** In lift mode *(platform raised), the machine is designed to operate on firm, level surfaces only.
 *** Gradeability applies to driving on slopes. See operator's manual for details regarding slope ratings.
 **** Weight will vary depending on options and/or country standards.

RANGE OF MOTION Z™-30/20N

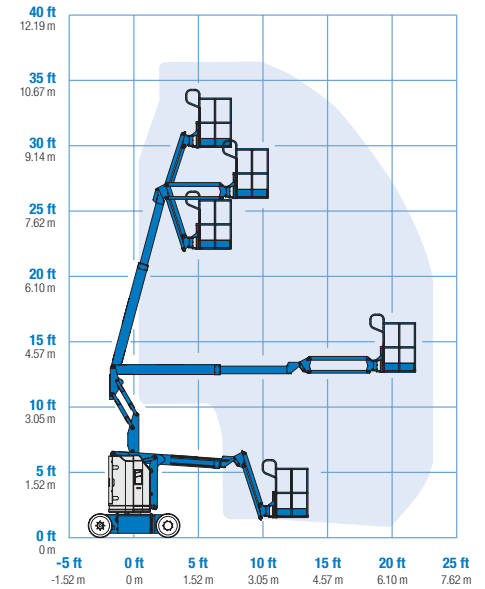

RANGE OF MOTION Z™-30/20N RJ

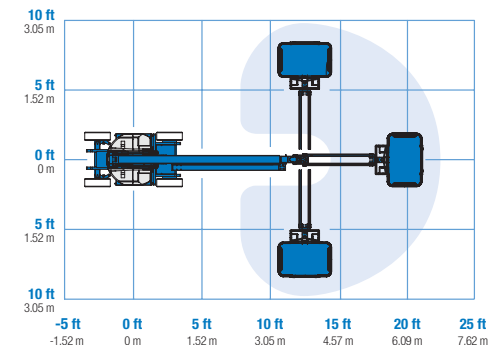
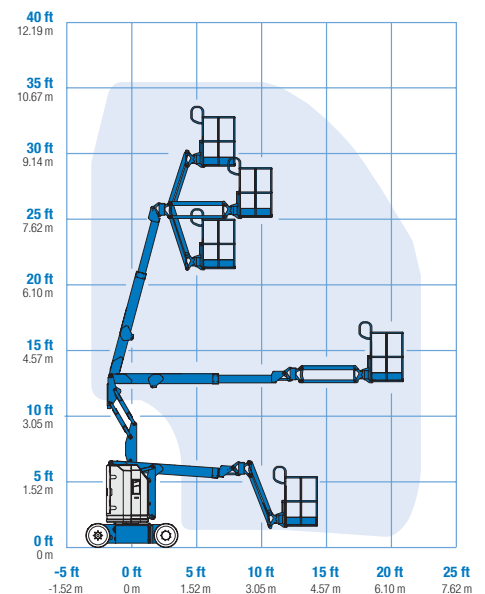

Features

EASILY CONFIGURED TO MEET YOUR NEEDS

PLATFORM

- Steel 3 ft 10 in (1.17 m)

JIB OPTIONS

- 4 ft (1.22 m) jib boom
- 4 ft (1.22 m) horizontal rotating jib boom

POWER

- 48 V DC power source

DRIVE

- 2WD

TIRE

- Solid rubber non-marking

STANDARD FEATURES

MEASUREMENTS

Z™-30/20N

- 36 ft (11.14 m) working height
- 21 ft 5 in (6.53 m) horizontal reach
- 12 ft 8 in (3.86 m) up and over clearance
- Up to 500 lb (227 kg) lift capacity

Z™-30/20N RJ

- 35 ft 2 in (10.89 m) working height
- 20 ft 6 in (6.25 m) horizontal reach
- 12 ft 8 in (3.86 m) up and over clearance
- Up to 500 lb (227 kg) lift capacity

PRODUCTIVITY

- 4 ft (1.22 m) jib boom with 139° working range
- Self-leveling platform
- Hydraulic platform rotation
- Fully proportional controls
- Thumb rocker steer
- Drive enable
- AC power cord to platform
- Horn
- Hour meter
- Tilt alarm
- Descent & travel alarms
- 355° non-continuous turntable rotation
- Zero tailswing and front arm swing

POWER

- 48 V DC deep cycle battery pack
- 24 V DC auxiliary power
- Universal 30A battery smart charger

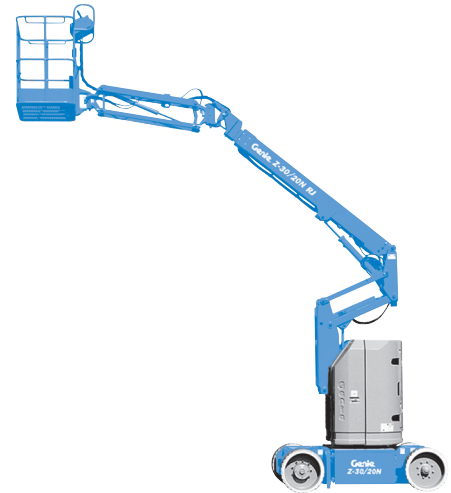

OPTIONS & ACCESSORIES

PRODUCTIVITY

- Platform swing gate
- Half-mesh platform inserts with swing gate
- Air line to platform
- Hostile environment package
- Fire resistant hydraulic oil
- Biodegradable hydraulic oil
- Tool tray
- Fluorescent tube caddy
- Pipe cradle (pair)
- Flashing beacon
- Platform work lights
- Lockable platform control box cover

POWER

- EE UL583 Fire Protection rating
- Battery charge indicator (BCI)
- Low voltage interrupt with BCI
- 800 watt 120VAC power inverter

Genie United States

18340 NE 76th Street
P.O. Box 97030
Redmond, Washington 98073-9730

Telephone **+1 (425) 881-1800**
Toll Free in USA/Canada **+1 (800) 536-1800**
Fax +1 (425) 883-3475

Genie Europe

The Maltings
Wharf Road
Grantham NG31 6BH
UK

Telephone **+44 (0)1476 584333**
Fax +44 (0)1476 584334

Email: AWP-InfoEurope@terex.com

Distributed By:



Blackrose Rentals

905 707-5111

www.blackroserentals.ca

Effective Date: January, 2010. Product specifications and prices are subject to change without notice or obligation. The photographs and/or drawings in this document are for illustrative purposes only. Refer to the appropriate Operator's Manual for instructions on the proper use of this equipment. Failure to follow the appropriate Operator's Manual when using our equipment or to otherwise act irresponsibly may result in serious injury or death. The only warranty applicable to our equipment is the standard written warranty applicable to the particular product and sale and we make no other warranty, express or implied. Products and services listed may be trademarks, service marks or trade-names of Terex Corporation, Genie Industries, Inc. and/or their subsidiaries in the U.S.A. and many other countries and all rights are reserved. Terex is a Registered Trademark of Terex Corporation in the U.S.A. and many other countries. Genie is a Registered Trademark of Genie Industries, Inc. in the U.S.A. and many other countries. Genie is a Terex Company. © 2010 Terex Corporation.