

# SERIES LP

# MODEL P-2



## DATA SHEET

**NET WEIGHT 92kg (203lbs)**  
**SHIPPING WEIGHTS 114kg (252lbs)**  
**IMPELLER DIA. 158,75mm (6.1/4")**  
**R.P.M. FROM 1150rpm TO 2900rpm**  
**MAX. SOLIDS 44,45mm (1.3/4")**

## SELF-PRIMING

1150 RPM 7,3m (24ft) - 1450 RPM 7,6m (25ft)  
 1750 RPM 7,6m (25ft) - 2050 RPM 7,6m (25ft)  
 2350 RPM 7,6m (25ft) - 2650 RPM 7,6m (25ft)  
 2650 RPM 7,6m (25ft) - 2900 RPM 7,6m (25ft)

BEFORE USING THIS TABLE, CHECK THE NPSH.

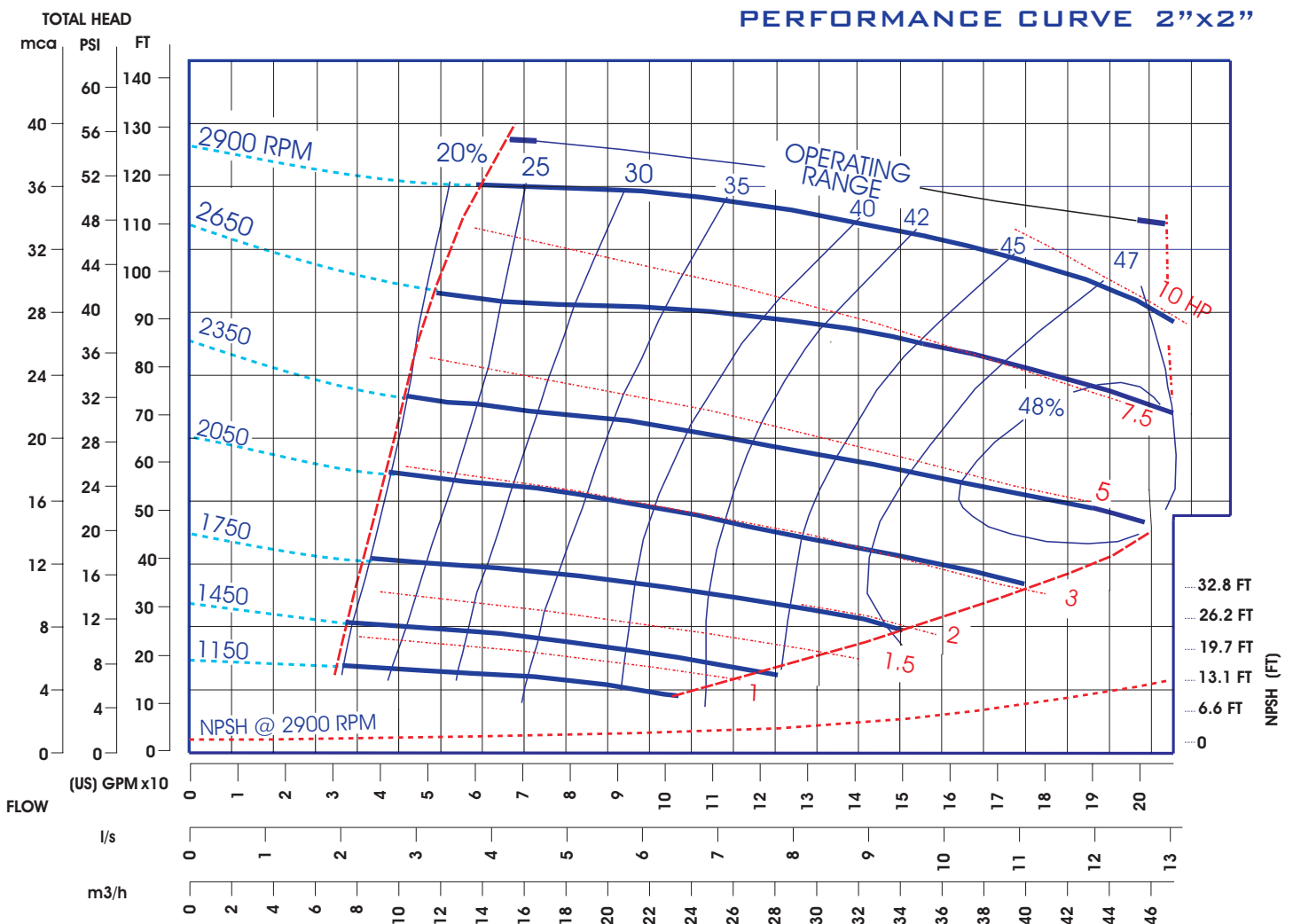



# SERIES P

# MODEL P-3



## DATA SHEET

**NET WEIGHT 183kg (404lbs)**  
**SHIPPING WEIGHTS 205kg (452lbs)**  
**IMPELLER DIA. 222,25mm (8.3/4")**  
**R.P.M. FROM 650rpm TO 2150rpm**  
**MAX. SOLIDS 63,5mm (2.1/2")**

## SELF-PRIMING

650 RPM 1,5m (5ft) - 750 RPM 1,8m (6ft)  
 850 RPM 2,4m (8ft) - 950 RPM 3,0m (10ft)  
 1050 RPM 4,0m (13ft) - 1150 RPM 4,9m (16ft)  
 1250 RPM 5,5m (18ft) - 1350 RPM 5,8m (19ft)  
 1450 RPM 6,4m (21ft) - 1550 RPM 6,4m (21ft)  
 1650 RPM 6,7m (22ft) - 1750 RPM 6,7m (22ft)  
 1850 RPM 7,6m (25ft) - 1950 RPM 7,6m (25ft)  
 2050 RPM 7,6m (25ft) - 2150 RPM 7,6m (25ft)

BEFORE USING THIS TABLE, CHECK THE NPSH.

## PERFORMANCE CURVE 3"x3"

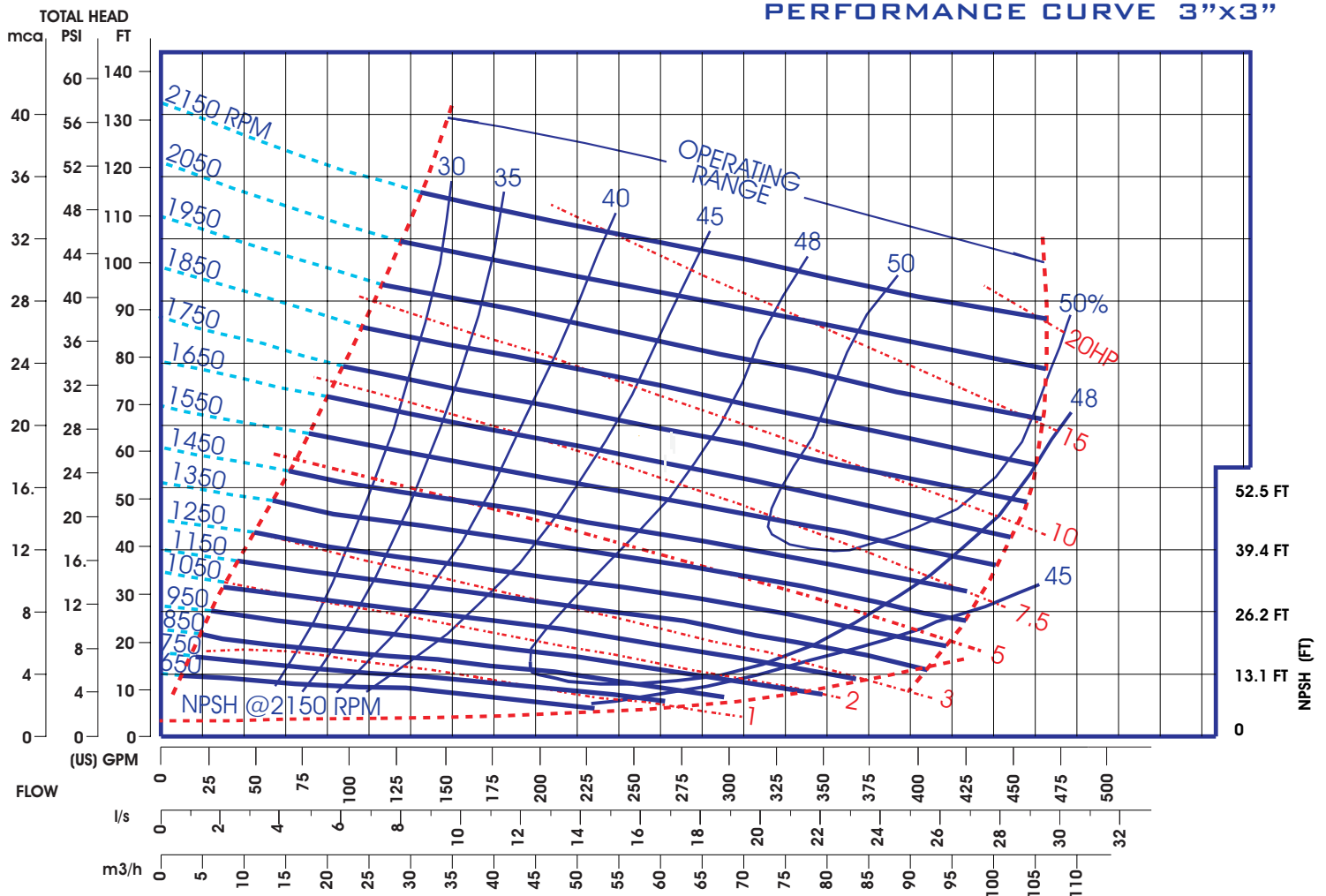

**EXTERNAL DIMENSIONS**  
MILLIMETERS (INCHES)

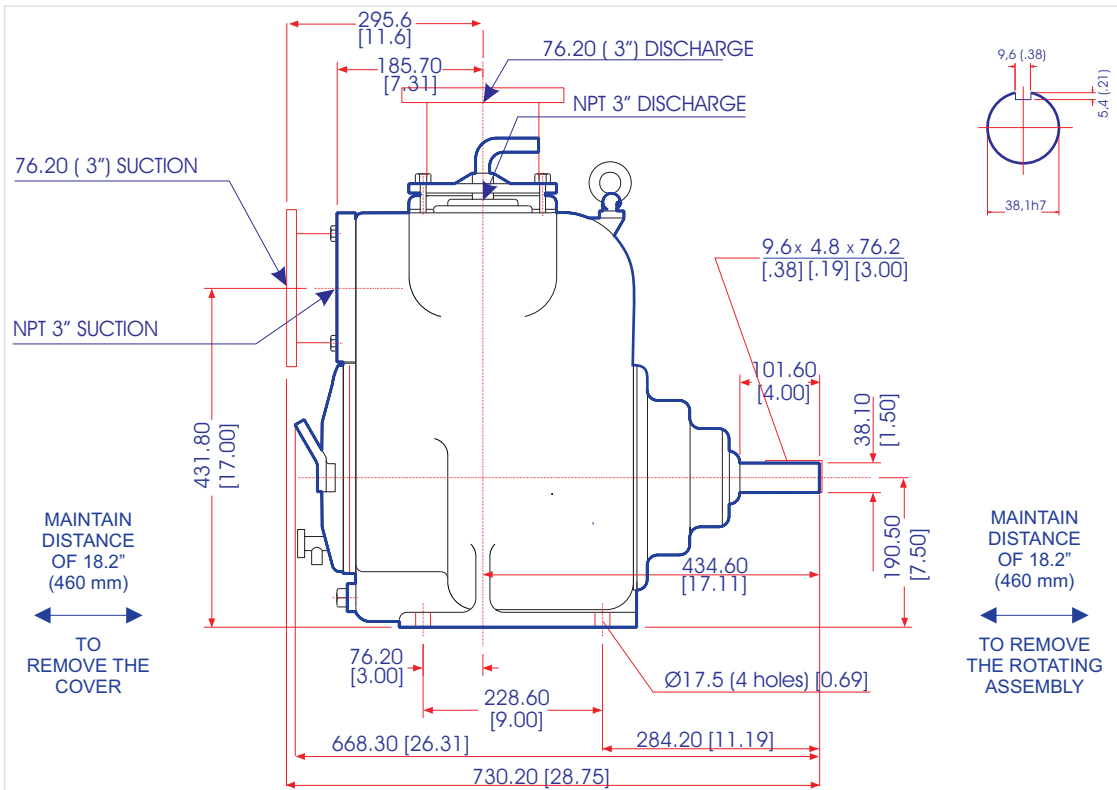
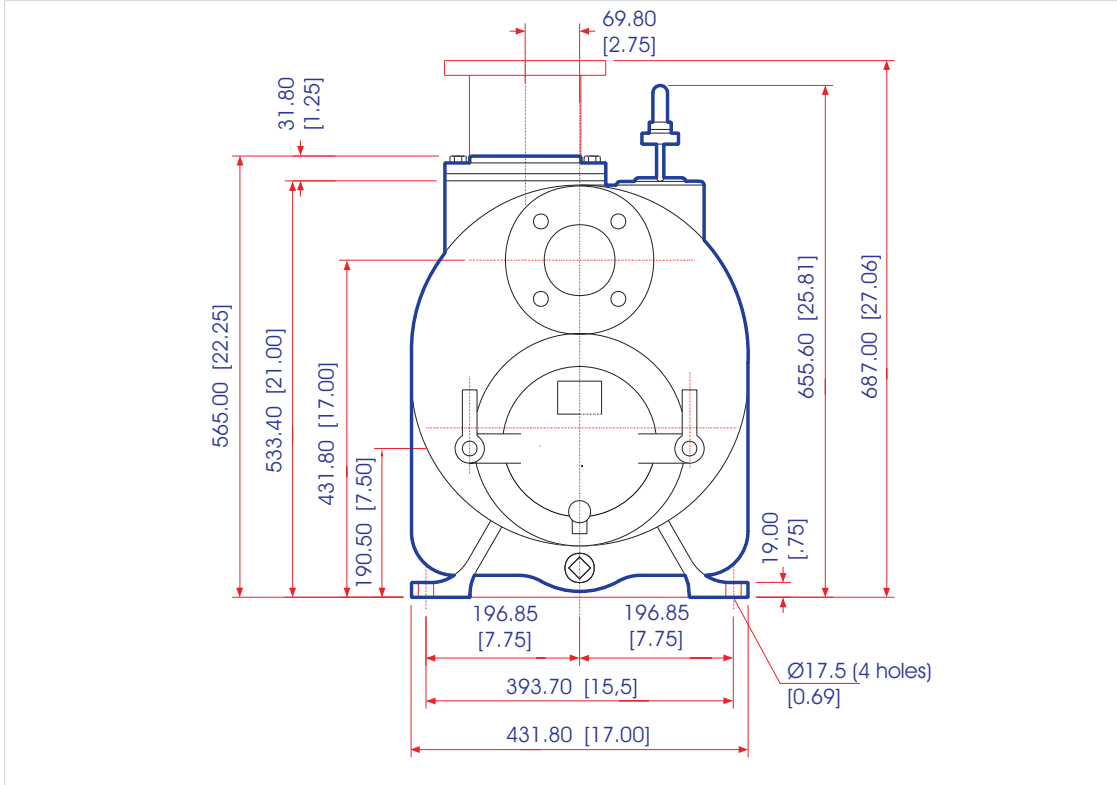

# SERIES P

# MODEL P-4



## DATA SHEET

**NET WEIGHT 259,5kg (600lbs)**  
**SHIPPING WEIGHTS 280kg (655lbs)**  
**IMPELLER DIA. 247,65mm (9.3/4")**  
**R.P.M. FROM 650rpm TO 1950rpm**  
**MAX. SOLIDS 76,2mm (3")**

## SELF-PRIMING

650 RPM 1,5m (5ft) - 750 RPM 2,4m (8ft)  
 850 RPM 4,9m (16ft) - 950 RPM 5,8m (19ft)  
 1050 RPM 6,7m (22ft) - 1150 RPM 7,3m (24ft)  
 1250 RPM 7,6m (25ft) - 1350 RPM 7,6m (25ft)  
 1450 RPM 7,6m (25ft) - 1550 RPM 7,6m (25ft)  
 1650 RPM 7,6m (25ft) - 1750 RPM 7,6m (25ft)  
 1850 RPM 7,6m (25ft) - 1950 RPM 7,6m (25ft)

BEFORE USING THIS TABLE, CHECK THE NPSH.

## PERFORMANCE CURVE 4"x4"

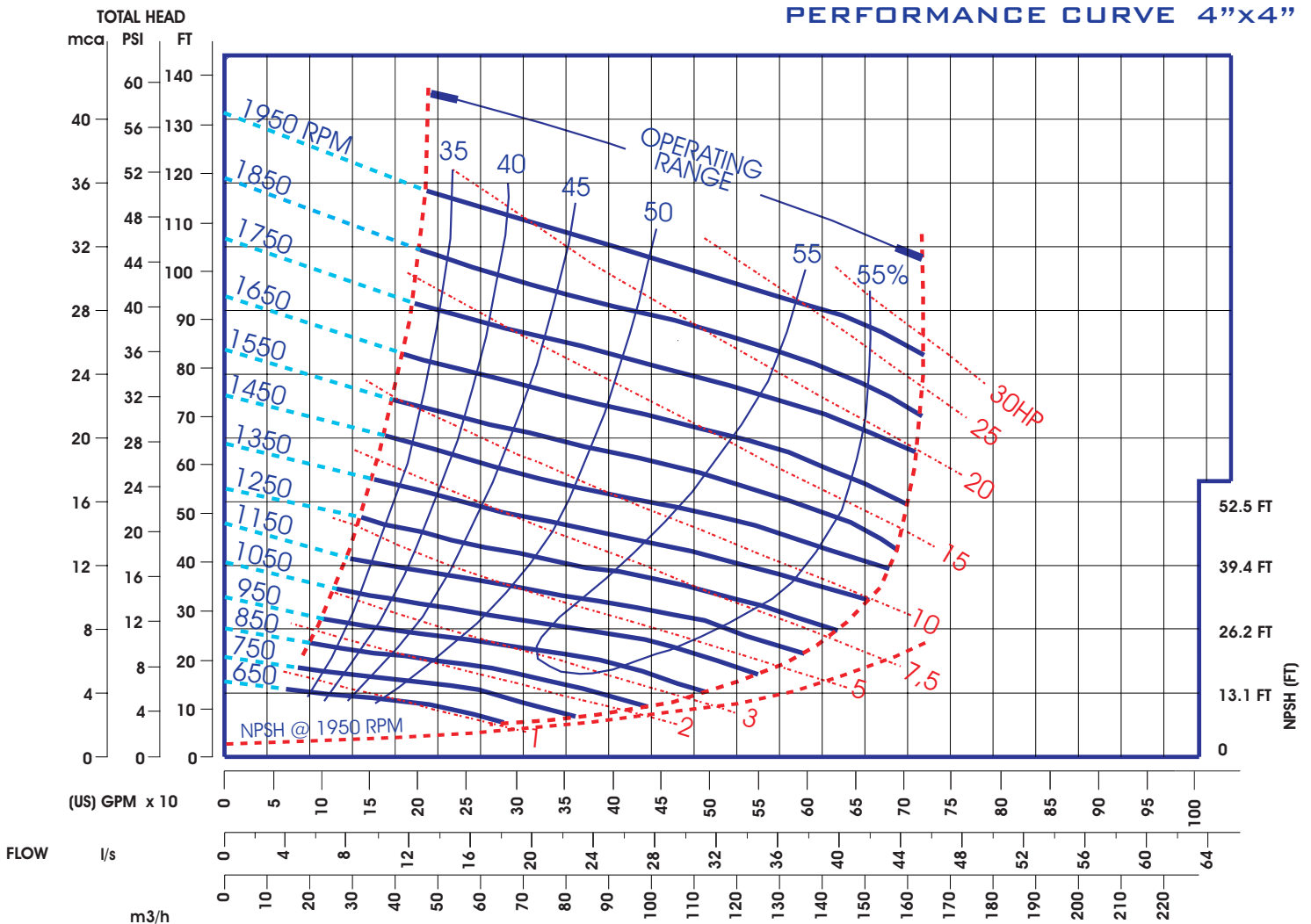



# SERIES P

# MODEL P-6



## DATA SHEET

**NET WEIGHT 364kg (802lbs)**  
**SHIPPING WEIGHTS 391kg (862lbs)**  
**IMPELLER DIA. 314,32mm (12.3/8")**  
**R.P.M. FROM 650rpm TO 1550rpm**  
**MAX. SOLIDS 76,2mm (3")**

### SELF-PRIMING

650 RPM 2,4m (8ft) - 750 RPM 2,7m (9ft)  
 850 RPM 3,6m (12ft) - 950 RPM 4,2m (14ft)  
 1050 RPM 5,5m (18ft) - 1150 RPM 6,4m (21ft)  
 1250 RPM 6,4m (21ft) - 1350 RPM 6,7m (22ft)  
 1450 RPM 7,0m (23ft) - 1550 RPM 7,6m (25ft)

BEFORE USING THIS TABLE, CHECK THE NPSH.

## PERFORMANCE CURVE 6"x6"

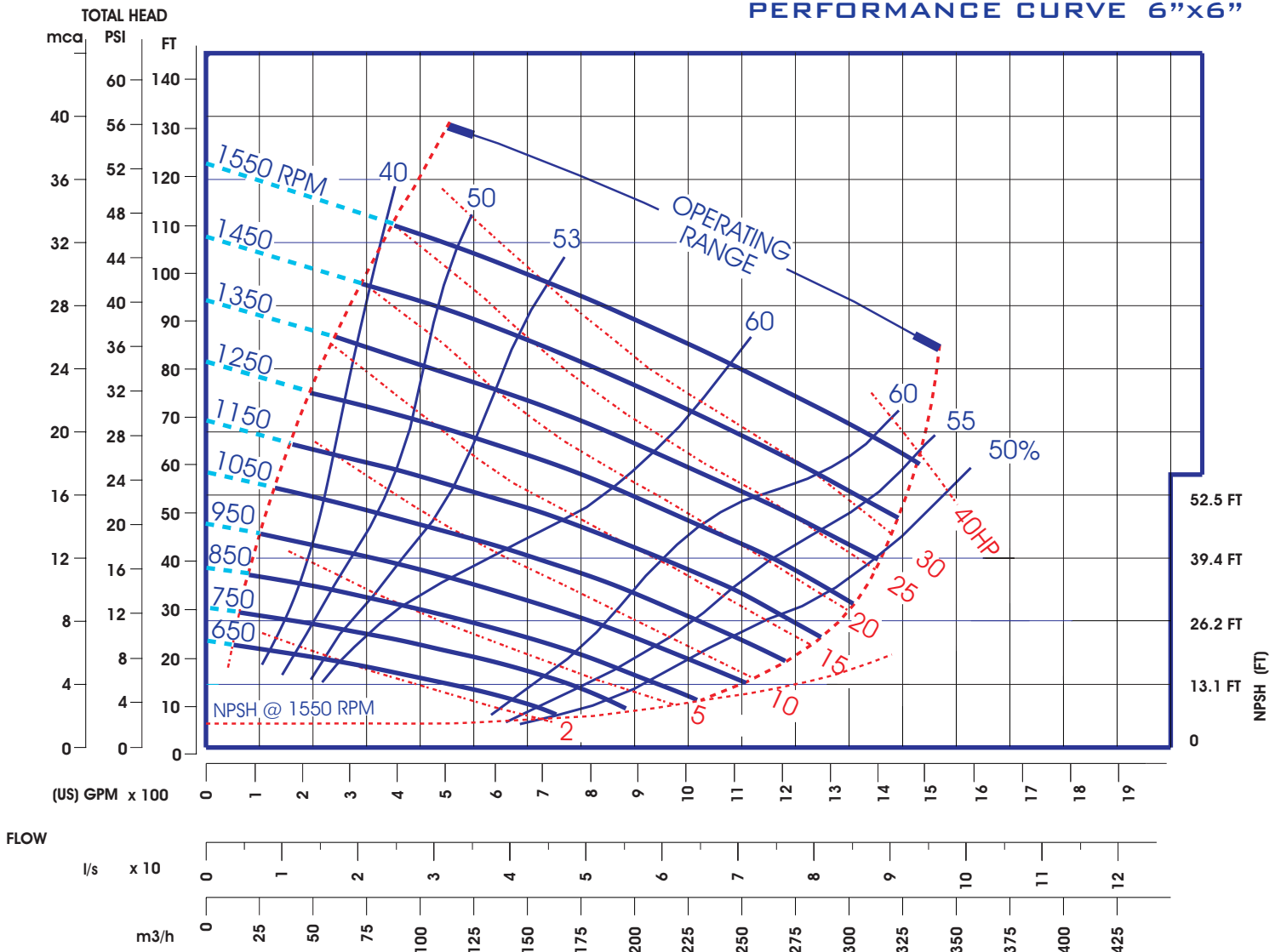

**EXTERNAL DIMENSIONS**  
MILLIMETERS (INCHES)

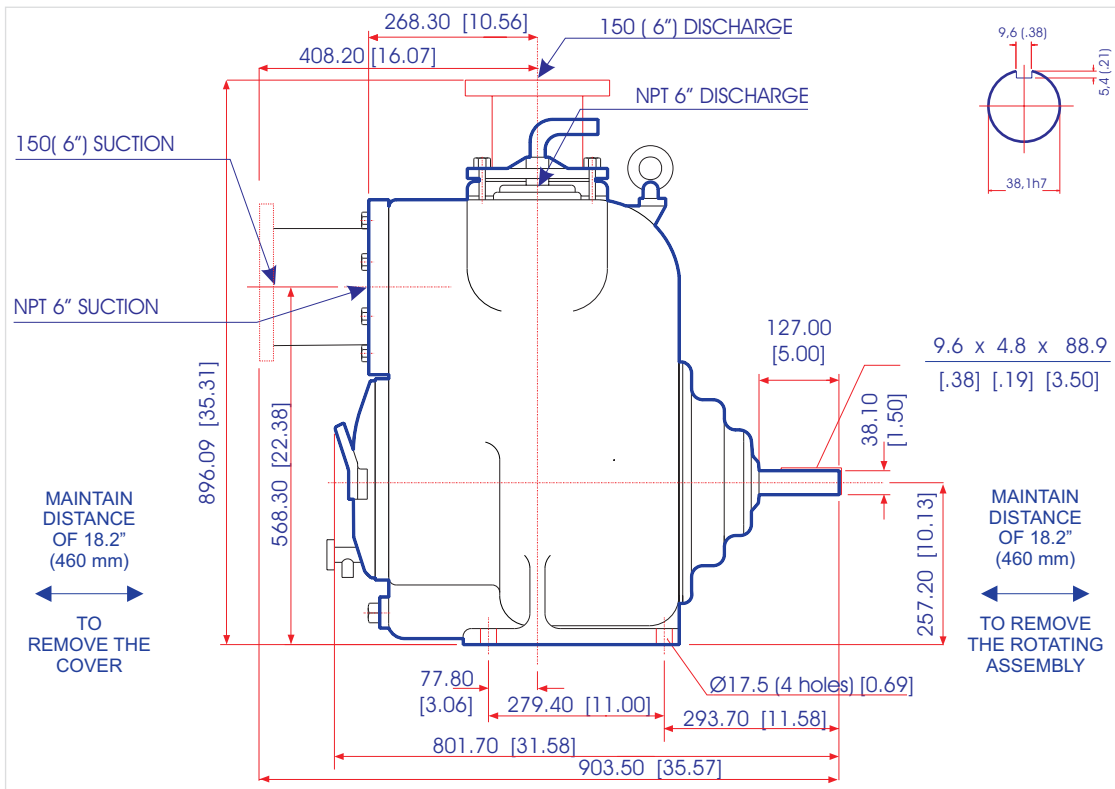
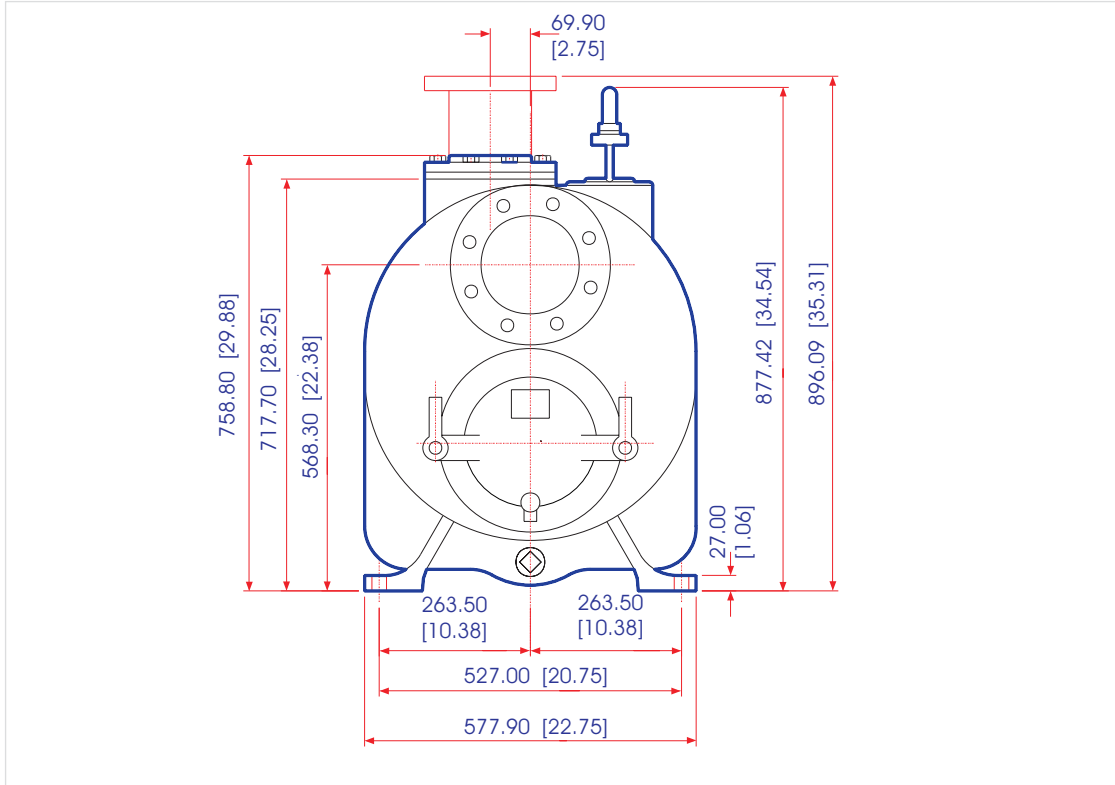

# SERIES P

# MODEL P-8



## DATA SHEET

**NET WEIGHT** 581 kg (1295 lbs)  
**SHIPPING WEIGHTS** 634 kg (1399 lbs)  
**IMPELLER DIA.** 374.65 mm (14.3/4")  
**R.P.M.** FROM 650rpm TO 1350rpm  
**MAX. SOLIDS** 76,2mm (3")

### SELF-PRIMING

650 RPM 2,7m (9ft) - 750 RPM 3,7m (12ft)  
 850 RPM 4,6m (15ft) - 950 RPM 5,2m (17ft)  
 1050 RPM 6,1m (20ft) - 1150 RPM 6,4m (21ft)  
 1250 RPM 6,7m (22ft) - 1350 RPM 7,0m (23ft)

BEFORE USING THIS TABLE, CHECK THE NPSH.

## PERFORMANCE CURVE 8"x8"

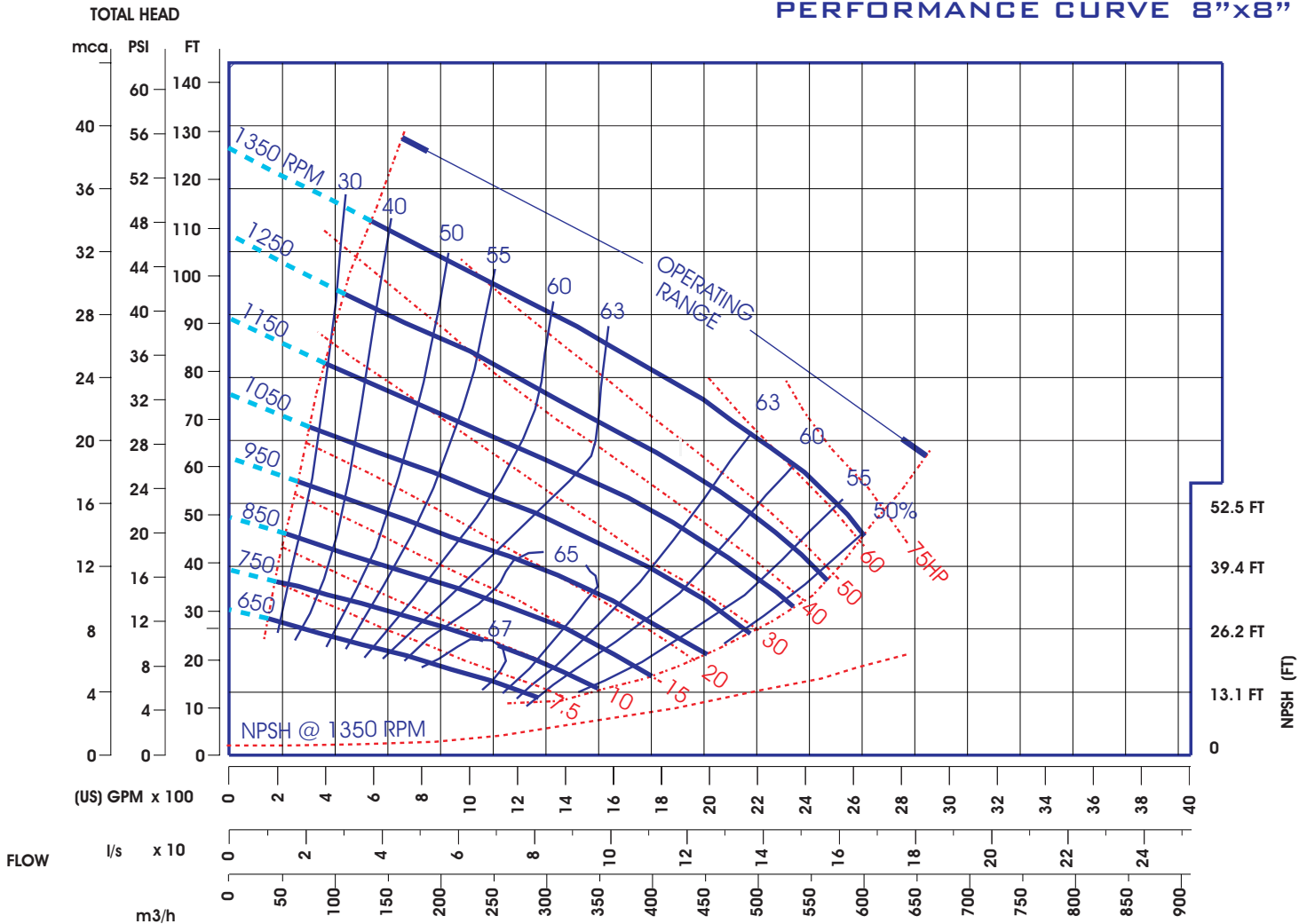

**EXTERNAL DIMENSIONS**  
MILLIMETERS (INCHES)

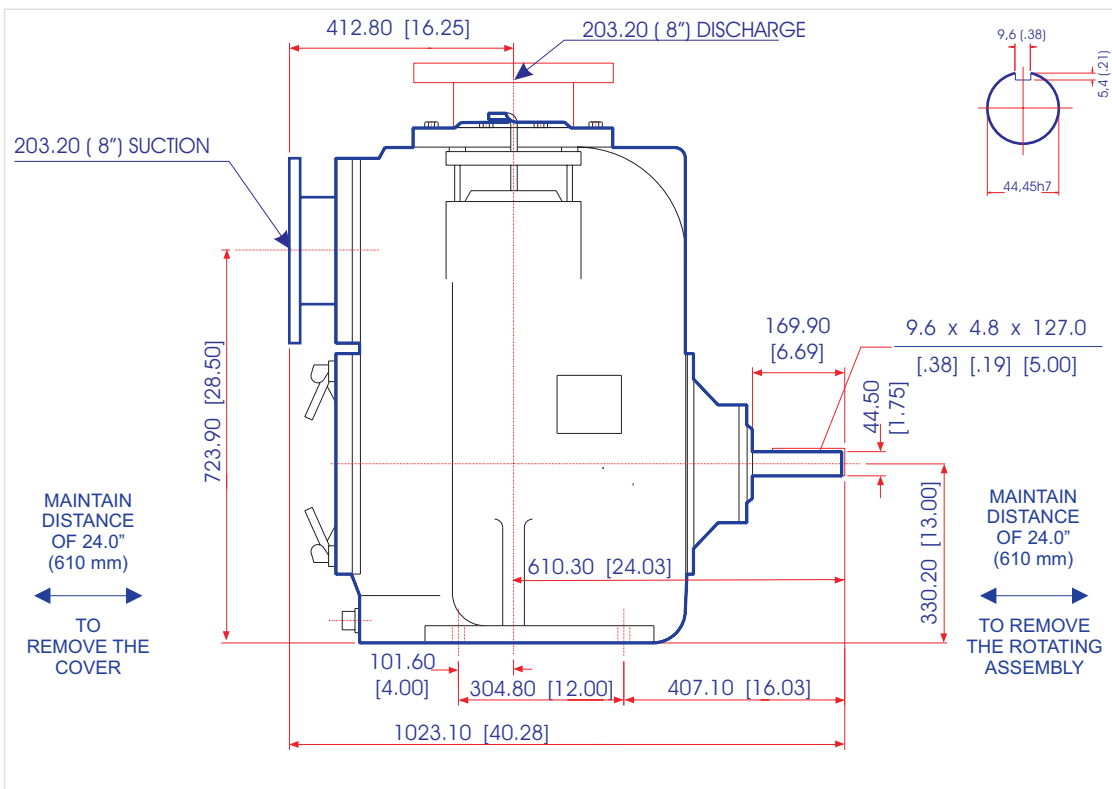
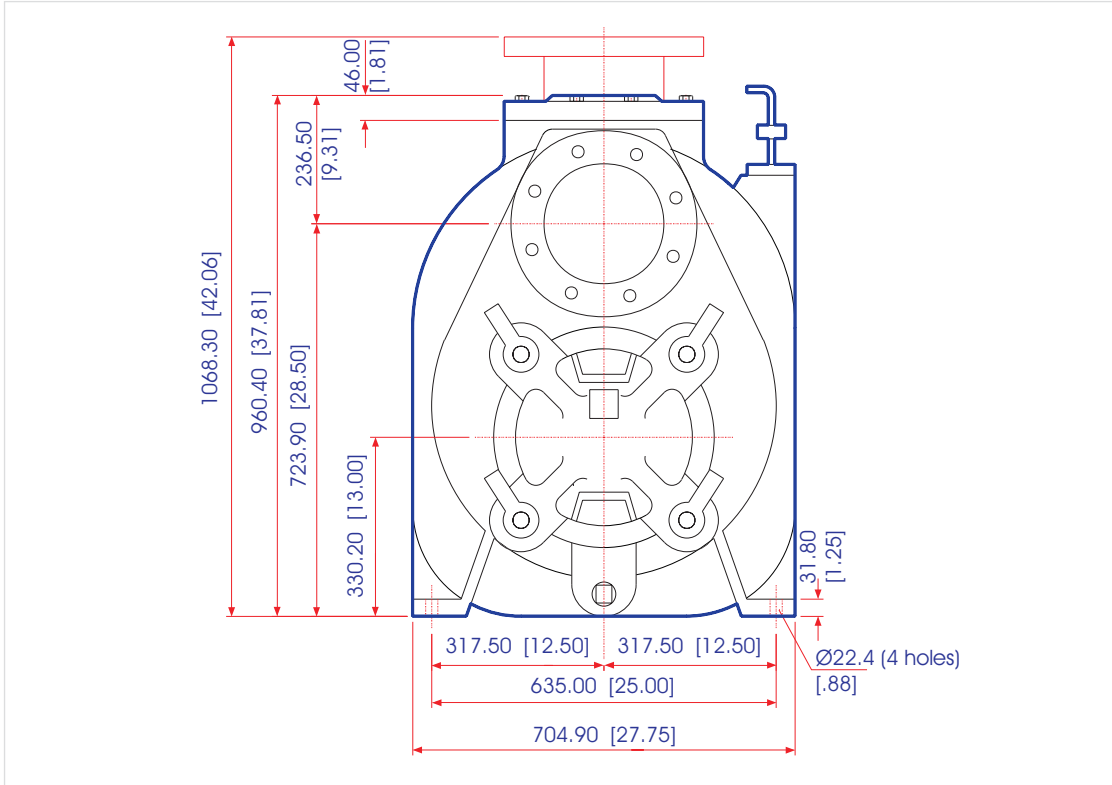

# SERIES P

# MODEL P-10



## DATA SHEET

**NET WEIGHT 635kg (1400lbs)**  
**SHIPPING WEIGHTS 663kg (1461lbs)**  
**IMPELLER DIA. 374,65mm (14.3/4")**  
**R.P.M. FROM 650rpm TO 1450rpm**  
**MAX. SOLIDS 76,2mm (3")**

### SELF-PRIMING

650 RPM 2,1m (7ft) - 750 RPM 3,4m (11ft)  
 850 RPM 4,3m (14ft) - 950 RPM 5,2m (17ft)  
 1050 RPM 5,5m (18ft) - 1150 RPM 5,5m (18ft)  
 1250 RPM 5,8m (19ft) - 1350 RPM 6,7m (22ft)  
 1450 RPM 6,7m (22ft)

BEFORE USING THIS TABLE, CHECK THE NPSH.

## PERFORMANCE CURVE 10"X10"

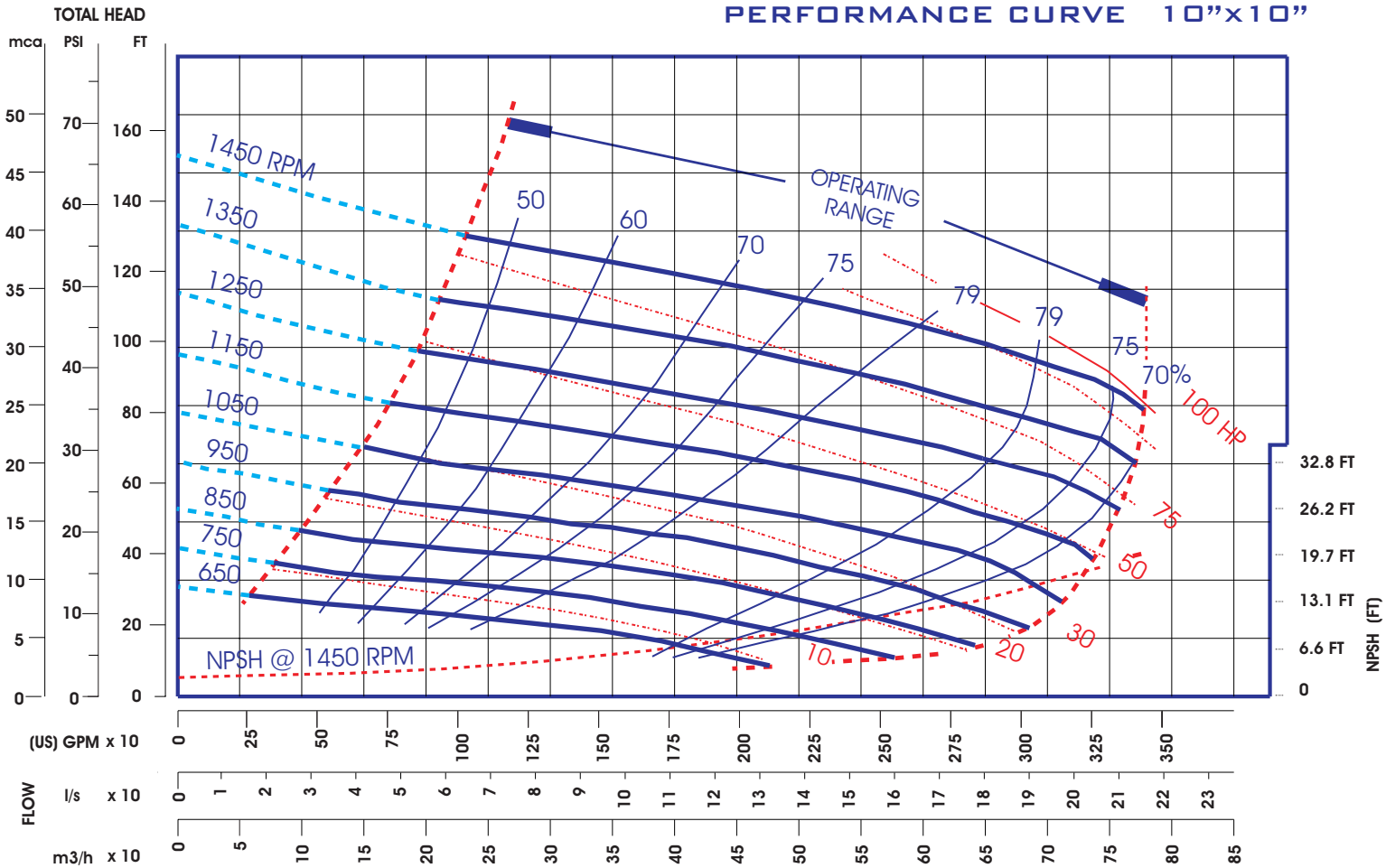



# SERIES P

# MODEL P-12



## DATA SHEET

NET WEIGHT **998kg (2200lbs)**  
 SHIPPING WEIGHTS **1066kg (2350lbs)**  
 IMPELLER DIA. **457,2mm (18")**  
 R.P.M. **FROM 650rpm TO 1250rpm**  
 MAX. SOLIDS **76,2mm (3")**

## SELF-PRIMING

650 RPM 1,6m (5ft) - 750 RPM 2,7m (9ft)  
 850 RPM 3,9m (13ft) - 950 RPM 4,5m (15ft)  
 1050 RPM 4,9m (16ft) - 1150 RPM 4,9m (16ft)  
 1250 RPM 4,9m (16ft)

BEFORE USING THIS TABLE, CHECK THE NPSH.

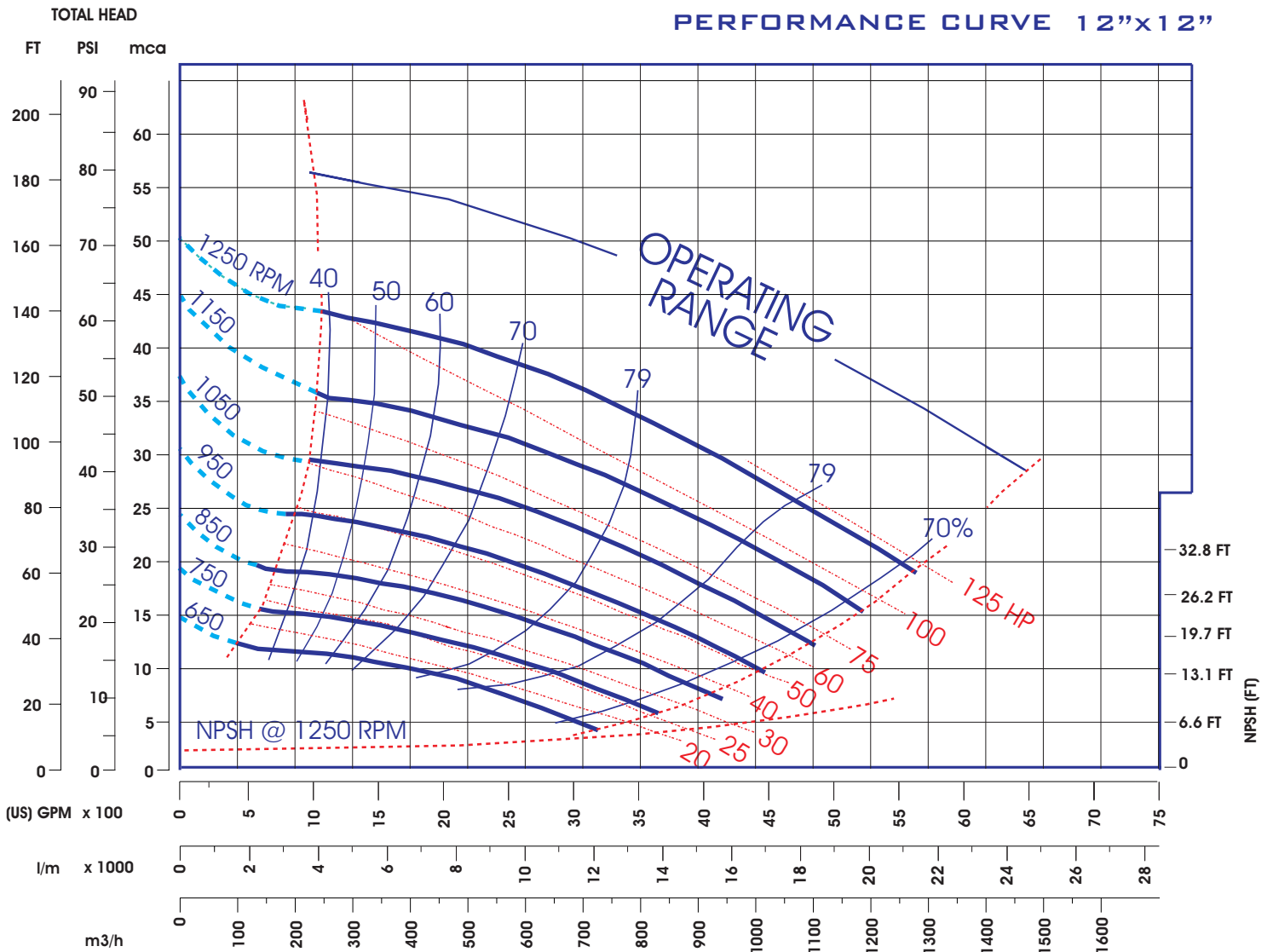

**EXTERNAL DIMENSIONS**  
MILLIMETERS (INCHES)

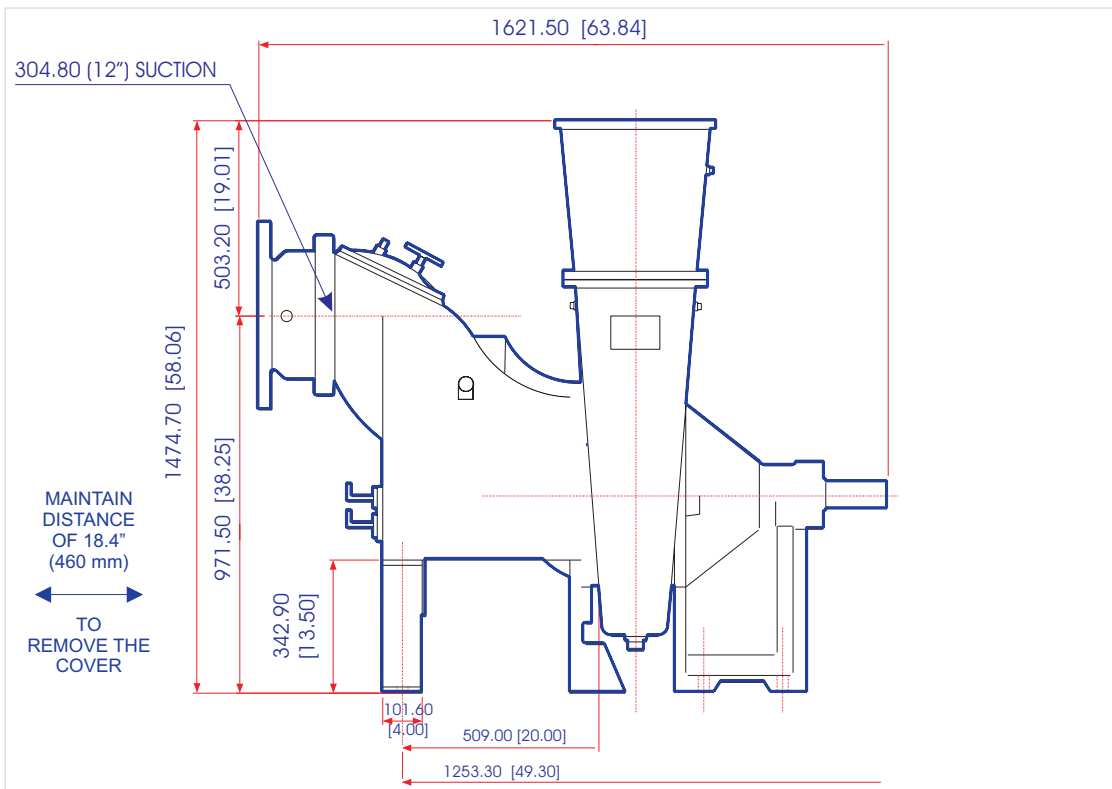
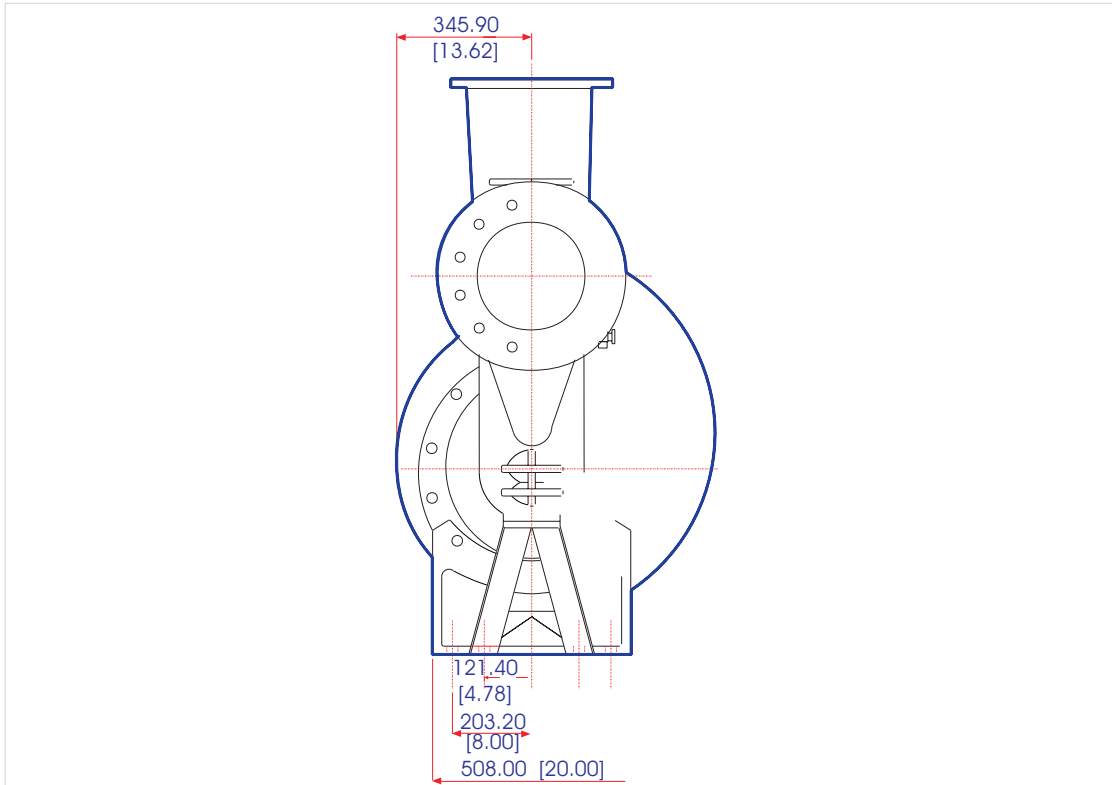

# SERIES H

# MODEL H-3



## DATA SHEET

NET WEIGHT **214kg (472lbs)**  
 SHIPPING WEIGHTS **225kg (497lbs)**  
 IMPELLER DIA. **279,4mm (11")**  
 R.P.M. **FROM 850rpm TO 2150rpm**  
 MAX. SOLIDS **20.63mm (13/16")**

## SELF-PRIMING

850 RPM 2,3m (7ft) - 1150 RPM 2,9m (9ft)  
 1450 RPM 4,5m (15ft) - 1750 RPM 7,6m (25ft)  
 1950 RPM 7,6m (25ft) - 2150 RPM 7,6m (25ft)

BEFORE USING THIS TABLE, CHECK THE NPSH.

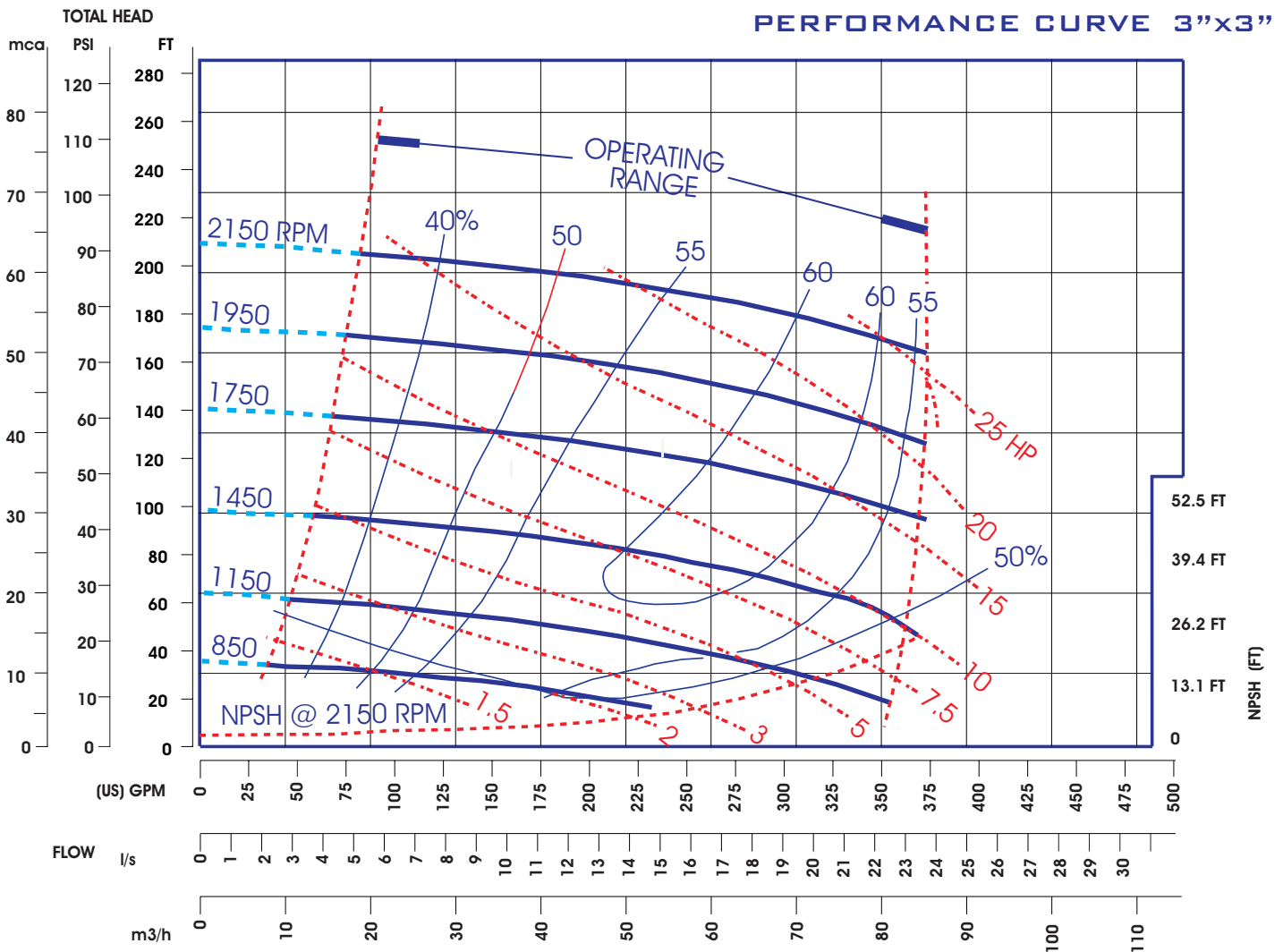



# SERIES H

# MODEL H-4



## DATA SHEET

**NET WEIGHT 272kg (600lbs)**  
**SHIPPING WEIGHTS 297kg (655lbs)**  
**IMPELLER DIA. 279,4mm (11")**  
**R.P.M. FROM 850rpm TO 2150rpm**  
**MAX. SOLIDS 28.57mm (1.1/8")**

## SELF-PRIMING

850 RPM 2,4m (8ft) - 1150 RPM 3,0m (10ft)  
 1450 RPM 3,6m (12ft) - 1750 RPM 3,9m (13ft)  
 1950 RPM 4,5m (15ft) - 2150 RPM 5,2m (17ft)

BEFORE USING THIS TABLE, CHECK THE NPSH.

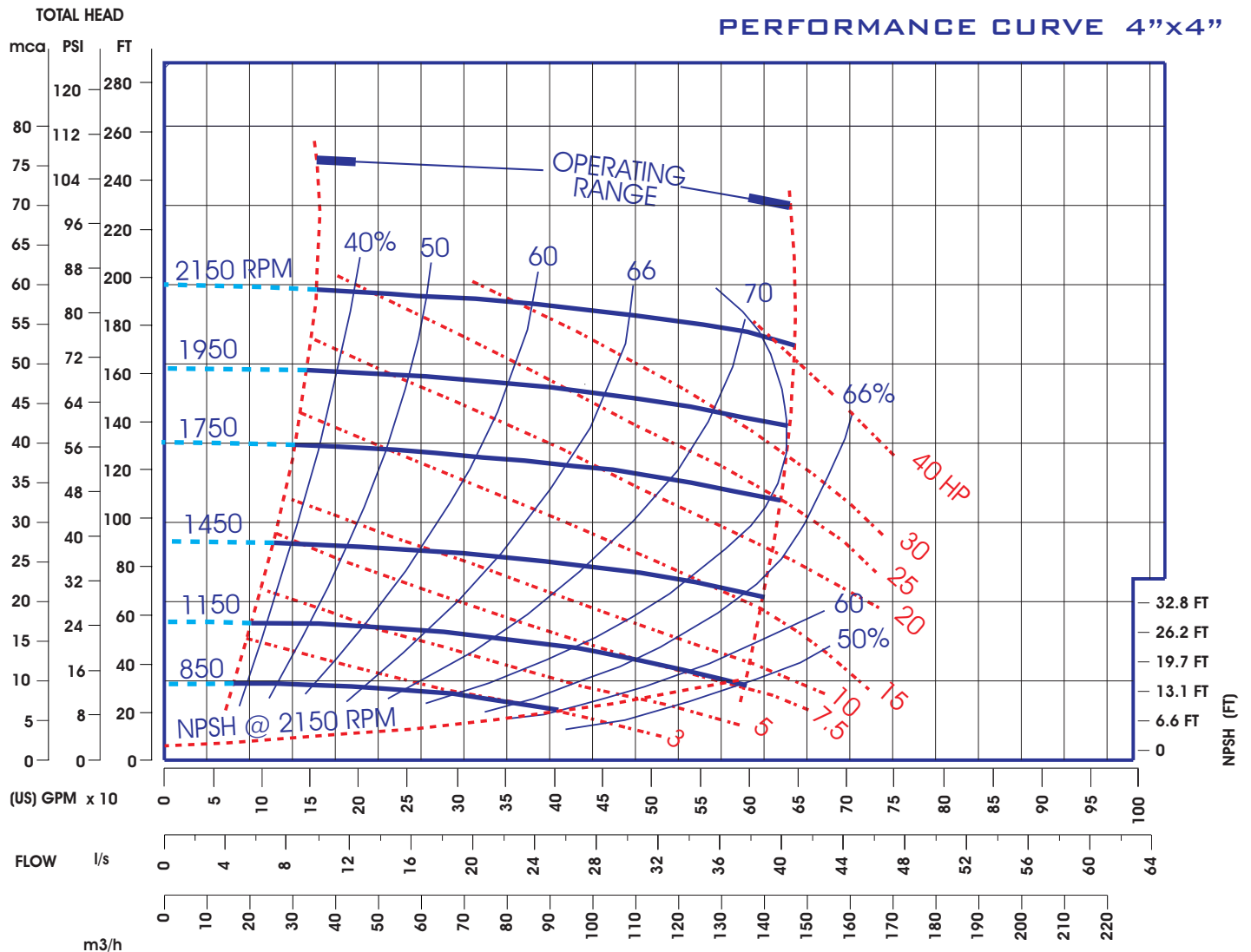

**SERIES H**

**MODEL H-4**

**EXTERNAL DIMENSIONS**

**MILLIMETERS (INCHES)**

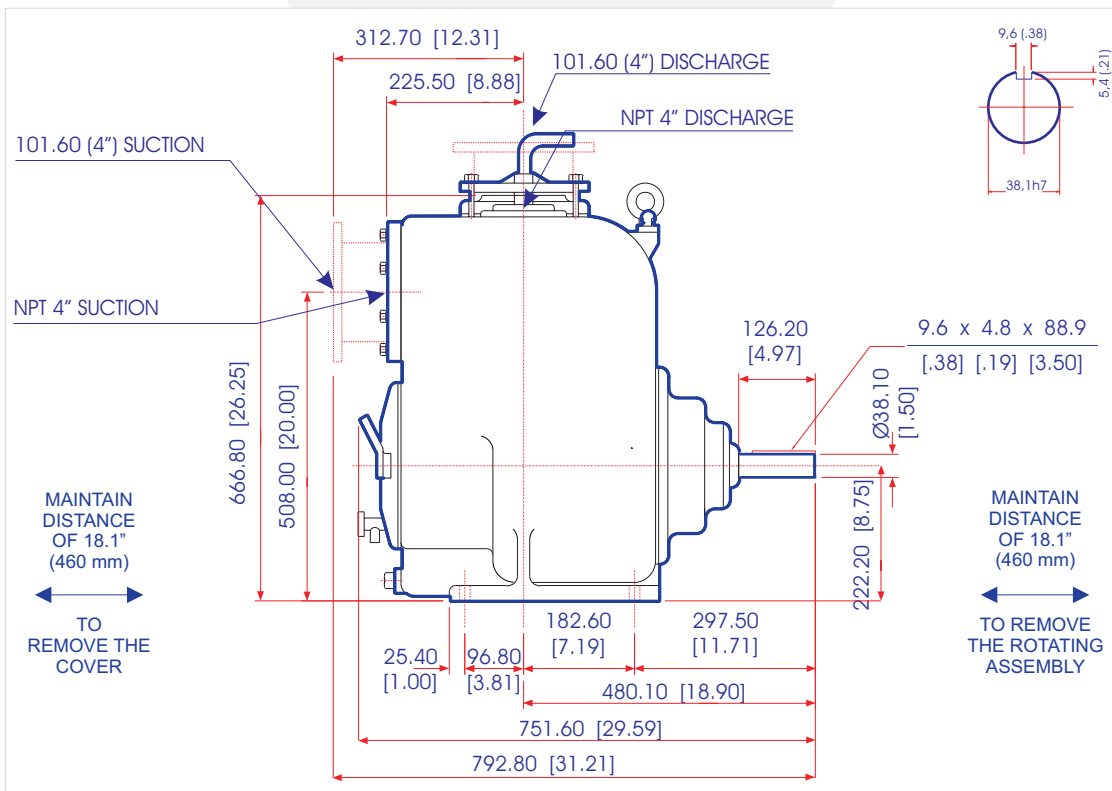
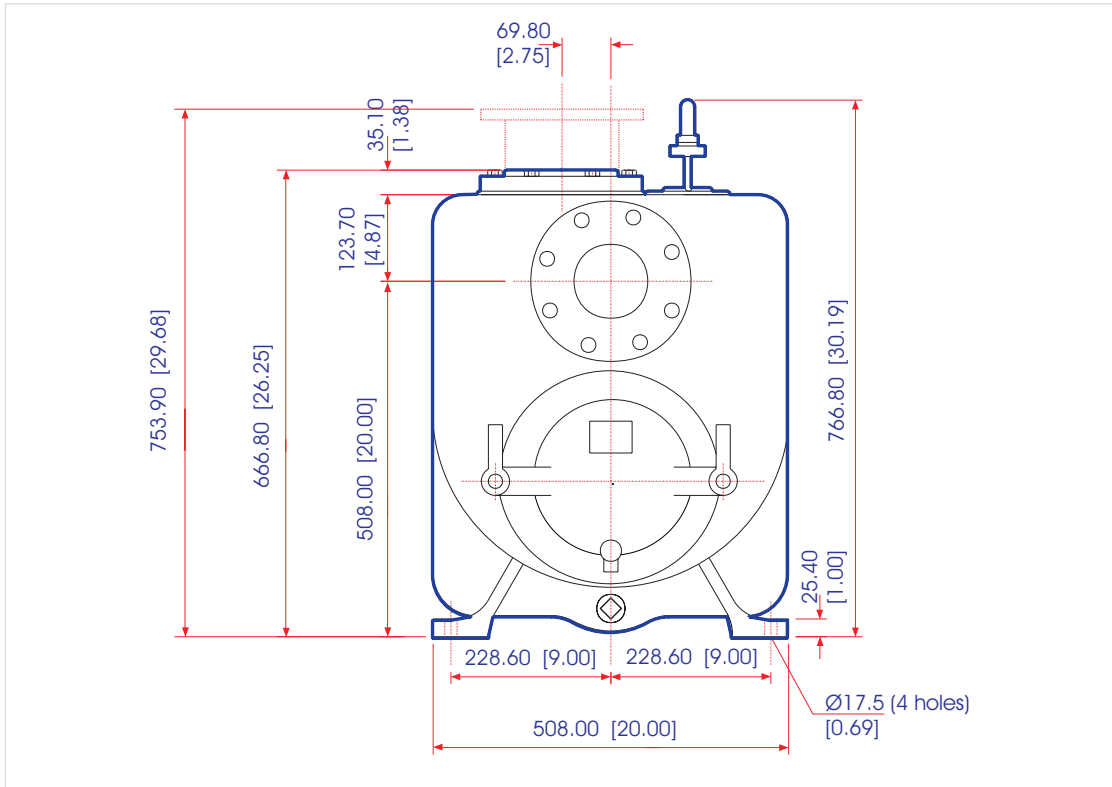

# SERIES H

# MODEL H-6



### DATA SHEET

NET WEIGHT **413kg (910lbs)**  
 SHIPPING WEIGHTS **437kg (965lbs)**  
 IMPELLER DIA. **317,5mm (12.1/2")**  
 R.P.M. **FROM 850rpm TO 1950rpm**  
 MAX. SOLIDS **31,75mm (1.1/4")**

### SELF-PRIMING

850 RPM 2,4m (8ft) - 1150 RPM 3,0m (10ft)  
 1450 RPM 4,2m (10ft) - 1750 RPM 4,5m (15ft)  
 1950 RPM 4,5m (15ft)

BEFORE USING THIS TABLE, CHECK THE NPSH.

### PERFORMANCE CURVE 6"x6"

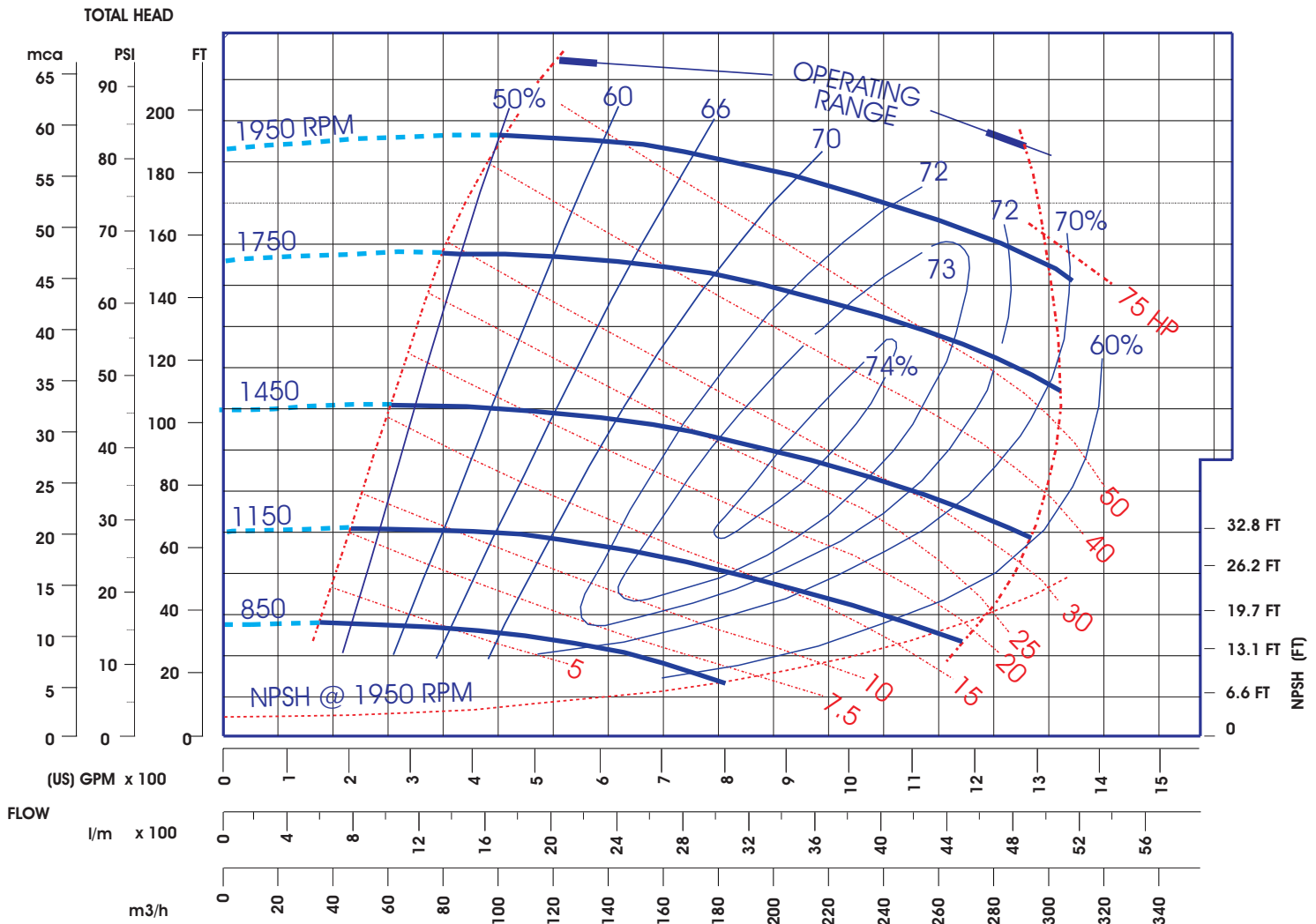

**EXTERNAL DIMENSIONS**  
MILLIMETERS (INCHES)

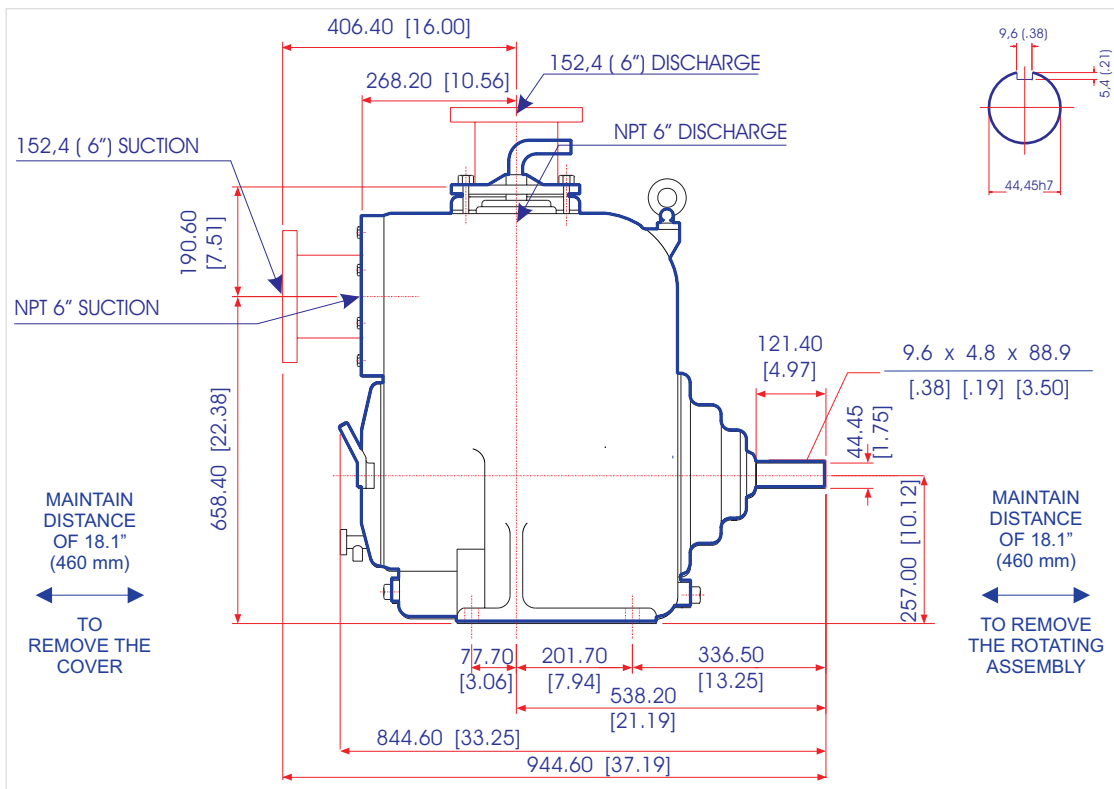
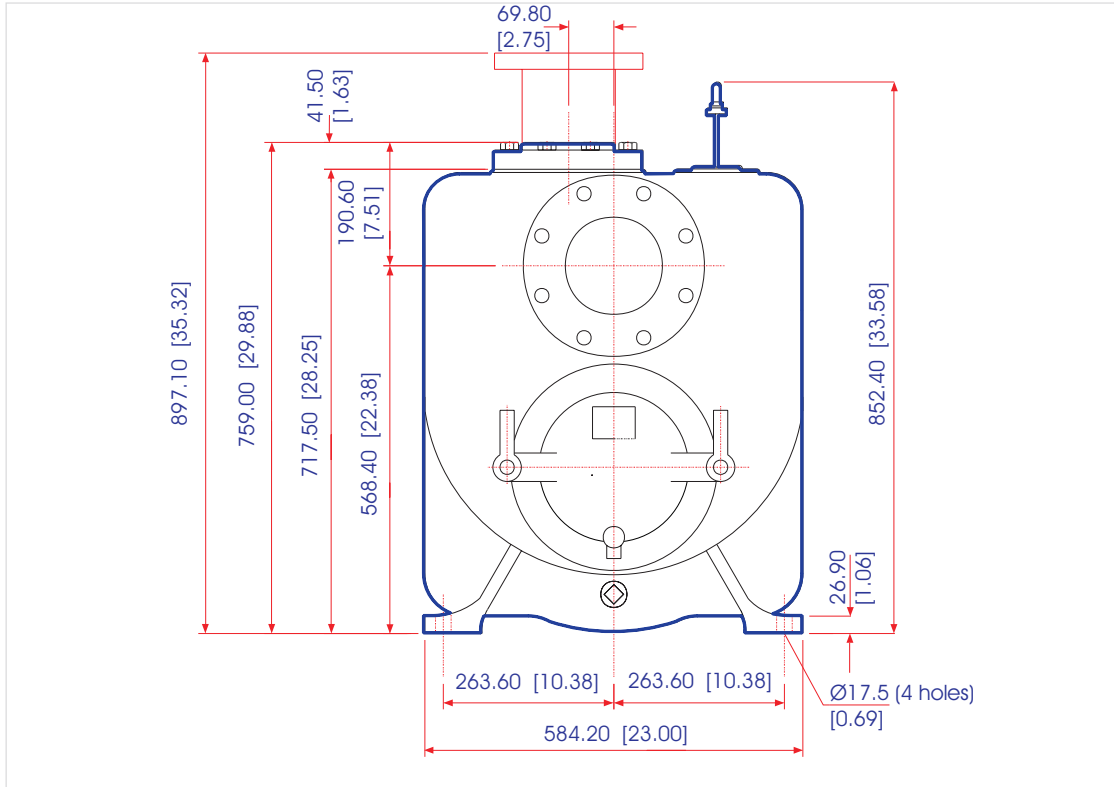

# STATION LIFT

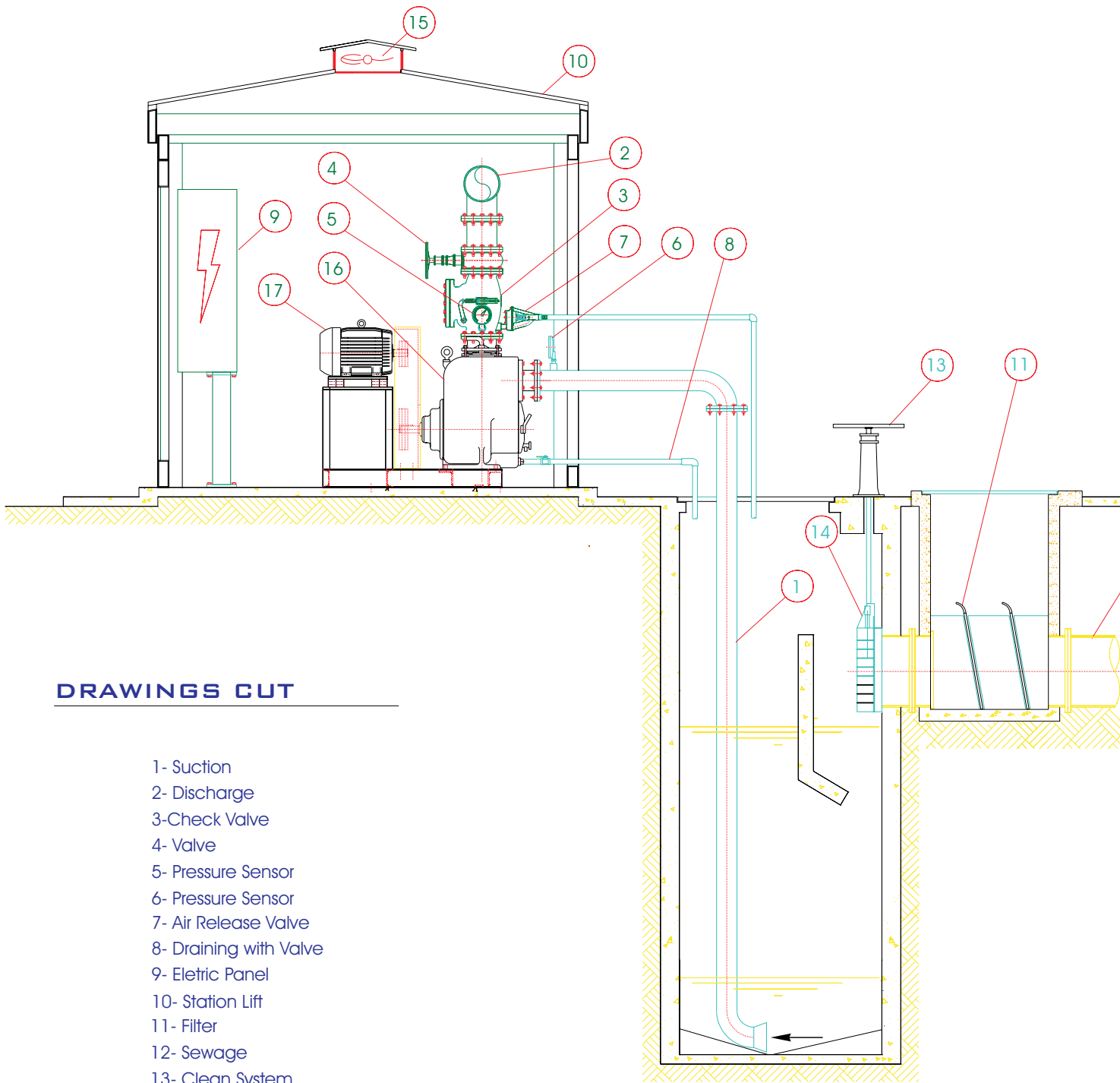

## DRAWINGS CUT

- 1- Suction
- 2- Discharge
- 3- Check Valve
- 4- Valve
- 5- Pressure Sensor
- 6- Pressure Sensor
- 7- Air Release Valve
- 8- Draining with Valve
- 9- Electric Panel
- 10- Station Lift
- 11- Filter
- 12- Sewage
- 13- Clean System
- 14- Valve
- 15- Fan
- 16- Esco Pump (Series P or H)
- 17- Electric Motor