

## 21 SCAFFOLDS

### Contents

1. Introduction
2. Problem areas
3. Selection
4. Basic types of scaffolds
5. Scaffold components
6. Erecting and dismantling scaffolds
7. Scaffold stability
8. Platforms
9. Proper use of scaffolds

### 1 INTRODUCTION

More than half of scaffold accidents in Ontario construction are falls. Several fatalities are also related to scaffolds each year. The number and severity of injuries involved make scaffold accidents one of the more serious safety problems in construction.

### 2 PROBLEM AREAS

The main problem areas are

- erecting and dismantling scaffolds
- climbing up and down scaffolds
- planks sliding off or breaking
- improper loading or overloading
- platforms not fully planked or “decked”
- platforms without guardrails
- failure to install all required components such as base plates, connections, and braces
- moving rolling scaffolds in the vicinity of overhead electrical wires
- moving rolling scaffolds with workers on the platform.

#### 2.1 Erecting and Dismantling

From 15 to 20% of scaffold-related injuries involve erecting and dismantling. The most common problem is the failure to provide an adequate working platform for a worker to use when installing the next lift of scaffold. Working from one or two planks is not recommended.

The next important consideration involves components, such as tie-ins, which you should install as the assembly progresses. Failure to do so makes the scaffold less stable and, while it may not topple, it may sway or move enough to knock someone off the platform. This happens more often when platforms are only one or two planks wide and guardrails are missing, as is frequently the case during erection and dismantling.

#### 2.2 Climbing Up and Down

Approximately 15% of scaffold-related injuries occur when workers are climbing up and down. Climbing up and down frames is a common but unacceptable practice that has resulted in numerous injuries and fatalities. Climbing up and down braces is also a frequent cause of accidents. You must provide adequate ladders to overcome this problem. In addition, workers must use proper climbing techniques (three-point contact).

#### 2.3 Planks Sliding Off or Breaking

Many scaffold injuries involve problems with planks. If scaffold planks are uncleaned or otherwise unsecured they easily slide off – this causes a surprising number of injuries. Scaffold planks can also break if they are in poor condition or overloaded. It is therefore important to use proper grades of lumber and to inspect planks before erection to ensure that there are no weak areas, deterioration, or cracks. Another common problem is insufficient or excessive overhang of planks at their support. Excessive overhang can cause a plank to tip up when a worker stands on the overhanging portion. Insufficient overhang is a leading cause of planks slipping off.

#### 2.4 Improper Loading or Overloading

Overloading causes excessive deflection in planks and can lead to deterioration and breaking. Overloading occurs most often in the masonry trade where skids of material can exceed 1500 kg (3000 lb.). If material is left overhanging the scaffold platform it can cause an imbalance leading to the scaffold overturning.

#### 2.5 Platforms Not Fully Decked

This situation is related to injuries not only during erection and dismantling but in general scaffold use. The Construction Regulation (Ontario Regulation 213/91) requires that all scaffold platforms must be at least 450 mm (18 inches) wide. All platforms above 2.4 metres (8 feet) must be fully decked.

#### 2.6 Platforms without Guardrails

Platforms without guardrails are a serious safety problem in construction. Guardrails are an important fall prevention measure not only for high platforms but also for low ones. Over one-third of the falls from scaffolds are from platforms less than 3 metres (10 feet) in height. Therefore, guardrails are recommended during normal use for all scaffold platforms over 1.5 metres (5 feet) high. Guardrails for all working platforms should consist of a top rail, a mid-rail, and a toeboard.

#### 2.7 Failure to Install All Required Components

Failure to use all of the proper scaffold components is a serious safety problem. Workers are more likely to cut corners when scaffolds are only a few frames in height. All too frequently they fail to install base plates, braces, proper securing devices such as “banana” clips or “pig tails” at the pins of frame scaffolds, and adequate tie-ins. Those erecting the scaffold must have all the necessary components, and must use them to ensure that the scaffold is safe. Furthermore, workers should install these parts as the scaffold erection progresses.

#### 2.8 Electrical Contact with Overhead Wires

Scaffolds seldom make contact with overhead electrical lines, but when it does happen it almost always results in a fatality. Failure to maintain safe distances from overhead powerlines while moving scaffolds is a major problem. Before attempting to move rolling scaffolds in outdoor open areas, check the route carefully to ensure that no overhead wires are in the immediate vicinity. Partial dismantling may be necessary in some situations to ensure that the scaffold will make the required safe

clearances from overhead powerlines. The required minimum safe distances are listed in Table 1. Hoisting scaffold material by forklift or other mechanical means requires careful planning and should be avoided in the vicinity of powerlines. Transporting already-erected scaffolds by forklift, particularly in residential construction, has been the cause of many electrical contacts — this is a dangerous practice. Workers handling materials or equipment while working on the platform must also take care to avoid electrical contact.

Table 1: Minimum distance from powerlines

Voltage Rating of Power Line	Minimum Distance
750 to 150,000 volts	3 metres (10 feet)
150,001 to 250,000 volts	4.5 metres (15 feet)
over 250,000 volts	6 metres (20 feet)

### 2.9 Moving Rolling Scaffolds with Workers on the Platform

Moving rolling scaffolds with workers on the platform can be dangerous. Where it is impractical for workers to climb down, and the scaffold is over 3 metres (10 feet) in height, each worker must be tied off with a full body harness and lanyard. Lifelines must be attached to a suitable anchor point other than the scaffold. Holes, depressions, curbs, etc. have all been responsible for scaffolds overturning while being moved. In some jurisdictions moving a scaffold with workers on the platform is prohibited if the platform exceeds a certain height.

## 3 SELECTION

The safe and efficient use of scaffolding depends first on choosing the right system for the job. If the scaffold's basic characteristics are unsuited to the task, or if all the necessary components are not available, personnel are forced to make do and improvise. These conditions lead to accidents.

Proper selection of scaffolding and related components requires basic knowledge about site conditions and the work to be done. Considerations include

- weight of workers, tools, materials, and equipment to be carried by the scaffold
- site conditions (e.g., interior, exterior, backfill, concrete floors, type and condition of walls, access for the equipment, variations in elevation, anchorage points)
- height or heights to which the scaffold may be erected
- type of work that will be done from the scaffold (e.g., masonry work, sandblasting, painting, metal siding, mechanical installation, suspended ceiling installation)
- duration of work
- experience of the supervisor and crew with the types of scaffolds available
- requirements for pedestrian traffic through and under the scaffold
- anticipated weather conditions
- ladders or other access to the platform
- obstructions
- configuration of the building or structure being worked on
- special erection or dismantling problems including providing practical fall protection for the erector

- the use of mechanical equipment to aid in erecting the scaffold.

## 4 BASIC TYPES OF SCAFFOLDS

### 4.1 Standard Tubular Frame Scaffolds

This is the most frequently used scaffold in construction. Historically it has been made of steel tubing, but aluminum is gaining popularity. The scaffold is manufactured in various configurations and spans. On some systems, ladder rungs are built into the end frames (Figure 4.1). These ladders are not suitable for tall scaffold towers unless rest platforms are installed at regular intervals and trapdoors are provided in the platforms. Other models are equipped with ladders that attach to the end frames (Figure 4.3). The ladder shown in Figure 4.3 is continuous and workers gain access via gates at the platform level. Again this ladder is not suitable for high scaffolds. Scaffolds in excess of 9 metres (30 feet) should have built-in stairs with rest platforms. Vertical ladders can reach up to 9 metres, but above 2.2 metres (7 feet) they require a safety cage.

The advantages of the frame scaffold are that it is simple to assemble, many construction trades are familiar with its use, and the components can be lifted manually by workers. However, as with other systems, all parts must be used. Failure to install any of the components, such as bracing and base plates, may lead to accidents.

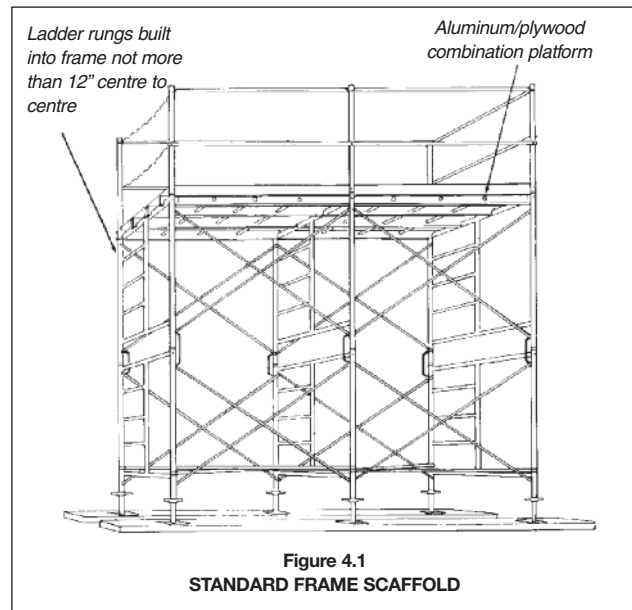

### 4.2 Standard Walk-through Frame Scaffolds

This is a variation of the standard tubular frame scaffold. An example is shown in Figure 4.2. Although primarily designed to accommodate pedestrian traffic at the ground or street level, the walk-through scaffold is frequently used by the masonry trade to provide greater height per tier and easier distribution of materials on platforms at intermediate levels.

### 4.2.1 Spans of Tower Base

Span lengths are varied using different lengths of vertical bracing. Most manufacturers have braces providing spans between 5 and 10 feet in length, with 7-foot spans being the most common. The use of 7-foot spans is ideal when using 16-foot planks as this allows a 1-foot overhang at each end. When using spans in excess of 7 feet, the load-bearing capacity of the platforms is reduced and must be accounted for in the design.

**Note:** Walk-through frame allows easier distribution of materials

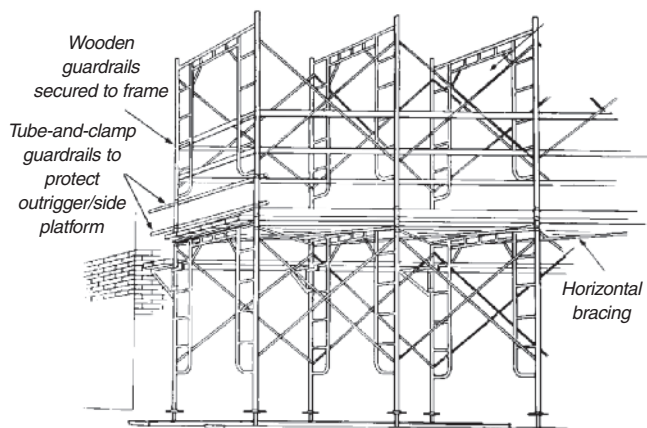

**Figure 4.2**  
WALK-THROUGH SCAFFOLD

### 4.3 Rolling Scaffolds

Rolling scaffolds are best suited where short-duration work must be carried out at multiple locations. They are used mainly by mechanical and electrical trades. There are two main types of rolling scaffold.

- Castor Type.** This type of scaffold is best suited for work on smooth floors and is typically used inside buildings. All castors should be equipped with braking devices (Figure 4.3). This kind of scaffold should be erected so that its height-to-width ratio is no greater than 3 to 1. This limits the height of platforms with standard outrigger stabilizers and single span towers to approximately 9 metres (30 feet).
- Farm Wagon Type.** Scaffolds erected on farm wagons or other devices with pneumatic tires are frequently used for installing sheet metal siding and similar materials on industrial buildings. For safe, effective use, the area around the building should be well compacted, relatively smooth and level. This type of scaffold must also have outrigger beams with levelling devices (Figure 4.4). It is subject to the 3-to-1 height-to-width ratio and is impractical for heights greater than 7.5 metres (25 feet). The scaffold should always be resting on the outriggers while workers are aboard. It should never be used as a work platform while it is "on rubber."

Rolling scaffolds other than those that are lifted off the ground on outriggers should have brakes on all wheels. All brakes should be applied when the scaffold reaches the desired location.

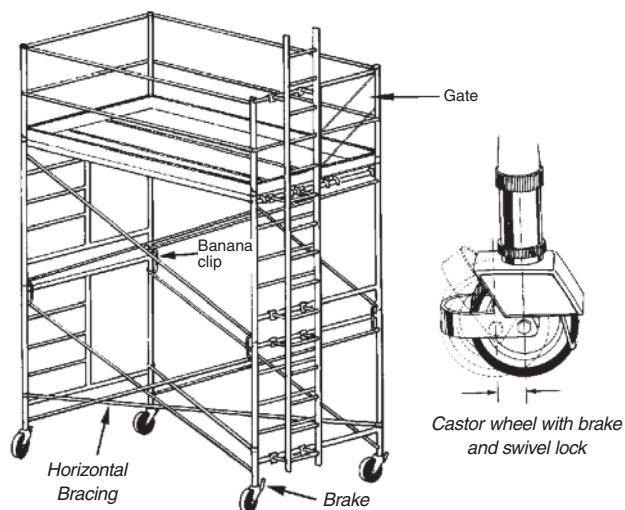

**Figure 4.3**  
ROLLING SCAFFOLD

**NOTE:** Screw jacks should be adjusted to lift wheels off ground before workers mount the scaffold.

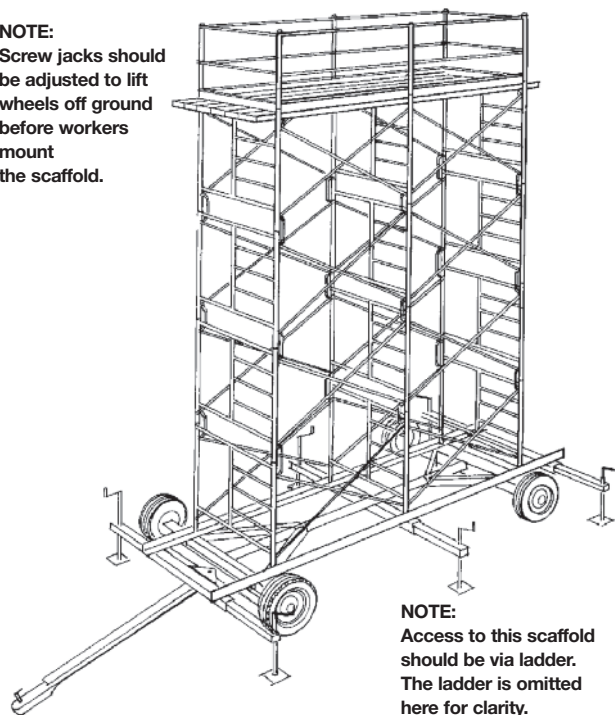

**Figure 4.4**  
FARM WAGON ROLLING SCAFFOLD

It is best not to move rolling scaffolds while a worker is on the platform. If people must remain on the platform when the scaffold is being moved they should be tied off to an independent structure using a fall-arrest system. In some jurisdictions moving a scaffold with workers on the platform is prohibited if the scaffold exceeds a certain height. The area through which the scaffold is to be moved should be free of bumps or depressions and cleared of all debris. Overhead hazards, especially powerlines, should be identified.

Rolling scaffolds should always have guardrails. They should also be securely pinned together and be fitted with horizontal bracing as recommended by the manufacturer.

Scaffolds that are not securely pinned together can separate if they drop into a hole or depression, or run into an obstacle at ground level. Horizontal bracing is necessary on a rolling tower scaffold to keep it from folding up because the connections between frames and braces are essentially pinned joints.

Castors should be secured to the frame. A castor dropping off in a hole or depression in floors has been the cause of serious accidents and injuries. Each castor should have a brake and swivel lock which are in good working order and can be applied easily. The castors or wheels should be suitable for the surface on which the scaffold is being used. Small wheels are suitable for pavement or concrete floors. You need larger pneumatic wheels when soils are the working surface. Before using rolling scaffolds, the surface must be smooth, free of depressions and reasonably level.

### 4.3.1 Electrical Contact

One of the biggest concerns with rolling scaffolds is the possibility of contact with overhead electrical wires. Scaffolds making accidental contact with powerlines have caused many deaths. Before moving a rolling scaffold, check the intended path of travel and maintain the required minimum clearances as set out in Table 1.

### 4.4 Fold-up Scaffold Frames

Fold-up scaffold frames (Figure 4.5) are frequently used by trades such as electricians, painters, and suspended ceiling erectors. Widths range from dimensions that will pass through a 750-mm (30-inch) opening to the standard width of about 1.5 metres (5 feet). Frequently made of aluminum, this type of scaffold is easily and quickly transported, erected, and moved about construction sites and from job to job. It should be used only on a smooth, hard surface.

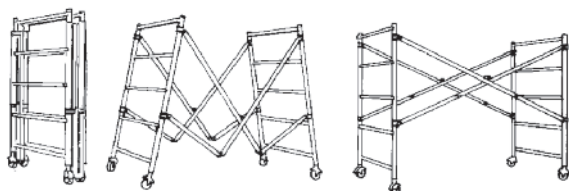

Figure 4.5  
FOLD-UP SCAFFOLD

### 4.5 Adjustable Scaffolds

Figure 4.6 illustrates another type of scaffold with uses similar to the fold-up model. Although it is not so easily erected, the system is light and very easily adjusted for height. It breaks down into a minimum of components readily transported from job to job. These devices should also be used only on smooth, hard surfaces. They are not intended to carry heavy loads.

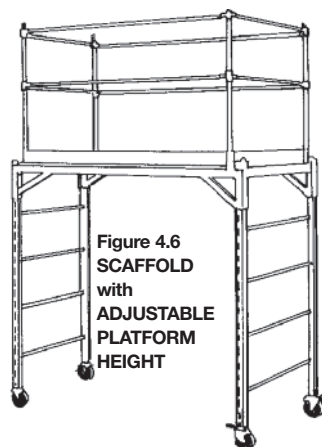

Figure 4.6  
SCAFFOLD  
with  
ADJUSTABLE  
PLATFORM  
HEIGHT

### 4.6 Tube-and-Clamp Scaffolds

Tube-and-clamp scaffolds (Figure 4.7) are frequently used where obstructions or non-rectangular structures are encountered. The scaffolds are infinitely adjustable in height and width. They can also be used for irregular and circular vertical configurations.

Personnel erecting tube-and-clamp scaffolds must be experienced. It is strongly recommended that, for each application, a sketch or drawing be prepared by someone who understands general structural design and the need for diagonal and cross bracing. In general, this type of scaffold takes longer to erect than the standard tubular frame type. Tube-and-clamp scaffolds above 10 metres (33 feet) must be designed by a professional engineer.

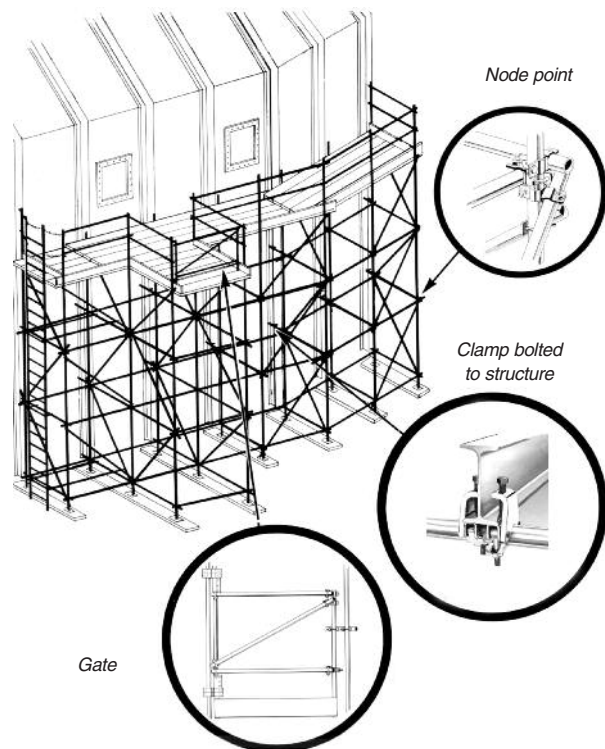

Figure 4.7  
TUBE-AND-CLAMP SCAFFOLD

### 4.7 Systems Scaffolds

European scaffold systems have become very popular in applications that were traditionally suited to tube-and-clamp. Although they are not as adjustable as tube-and-clamp scaffolds, they can be applied to a wide variety of non-rectangular, circular, or dome-shaped structures. A typical example is shown in Figure 4.8. As with tube-and-clamp scaffolds, personnel carrying out the erection should be experienced with that type of system and a sketch or drawing of the scaffold to be erected is recommended for each application. Systems scaffolds above 10 metres (33 feet) in height must be designed by a professional engineer.

There are a great many systems available, ranging from light-duty aluminum to heavy-duty steel support structures. They all employ different patented locking devices (wedges, locking pins, etc.) which are not intended to be interchanged with other systems.

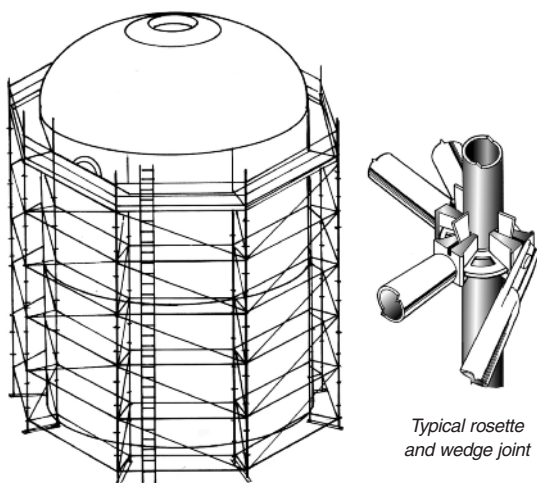

Figure 4.8  
SYSTEMS SCAFFOLD

#### 4.8 Mast-Climbing Work Platforms

The use of mast-climbing work platforms (Figure 4.9) is becoming increasingly common, particularly in the masonry industry. They are best suited for medium to high-rise projects, and are used also by siding installers, window installers, drywallers, and other trades. For low to medium-height projects they can be freestanding, depending on ground conditions and manufacturers' instructions. For high-rise applications they can be tied to the structure at regular intervals as set out by the manufacturer.

Mast-climbing work platforms can be used as a single tower or as multiple towers braced together. The platform climbs the mast, normally powered by an electric or gas engine. The climbing mechanism will have a failsafe system to prevent accidental lowering or failing of the platform.

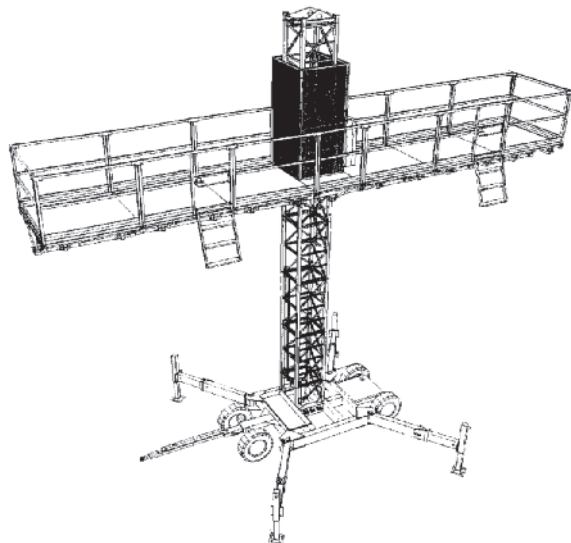

Figure 4.9  
MAST-CLIMBING WORK PLATFORM

Although not shown here, the working platform can be a set distance below the material platform. This allows material to be stacked at a convenient height for the worker. The entire platform can be raised to whatever height is required. As such it has significant ergonomic advantages.

Engineered drawings should accompany this work platform outlining such components as load capacity, tie-in requirements, and bracing.

The potential for fall-related accidents is reduced when using mast-climbing work platforms since workers stay on a wide, secured platform even during erection and dismantling.

**Manufacturers' instructions must be followed at all times.** A

competent worker should supervise the erection.

#### 4.9 Crank-up or Tower Scaffolds

Although crank-up scaffolds (Figure 4.10) are more popular in the United States, some Canadian masonry contractors use them. They consist of towers, bases, and platforms that can be lifted by winches.

The working platform is located 600 to 900 mm (2 to 3 feet) below the material platform, which is in an ergonomically good position for the worker.

The entire scaffold can be raised easily, allowing the worker a comfortable working height. Crews must be trained to erect, use, dismantle, and maintain tower scaffolding safely and efficiently. **Manufacturers' instructions must be followed at all times.** Tower scaffolds must be tied to the structure according to manufacturer's instructions.

### 5 SCAFFOLD COMPONENTS

**Tubular Frame Scaffolds:** There are many tubular frame scaffold components available (Figures 5.1, 5.2). Some components are necessary in almost all situations; others are optional depending on use and manufacturers' instructions. In addition to scaffold end frames, the minimum components required are

- base plates or castors
- mudsills
- adjustable screw jacks
- vertical braces on both sides of frames unless

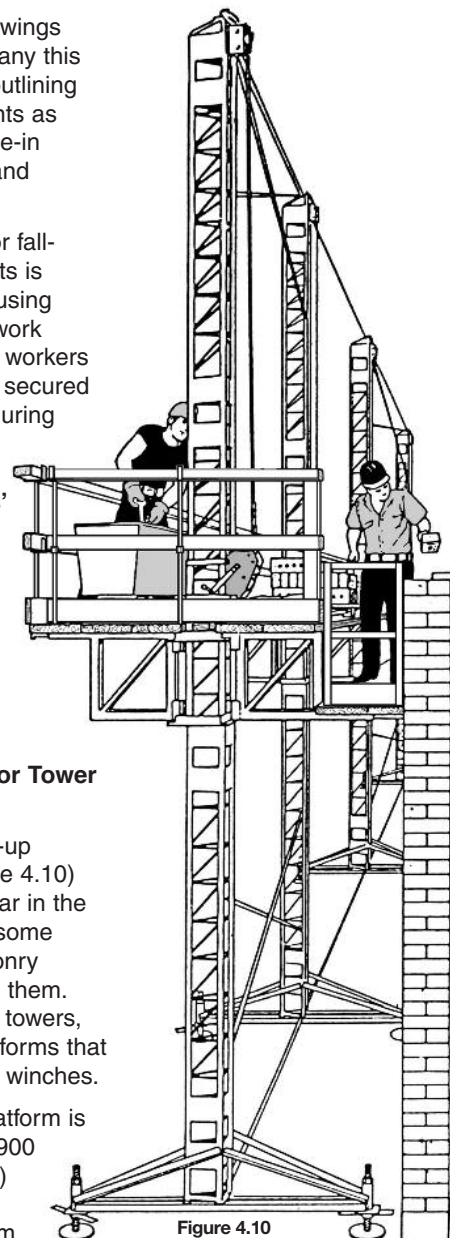
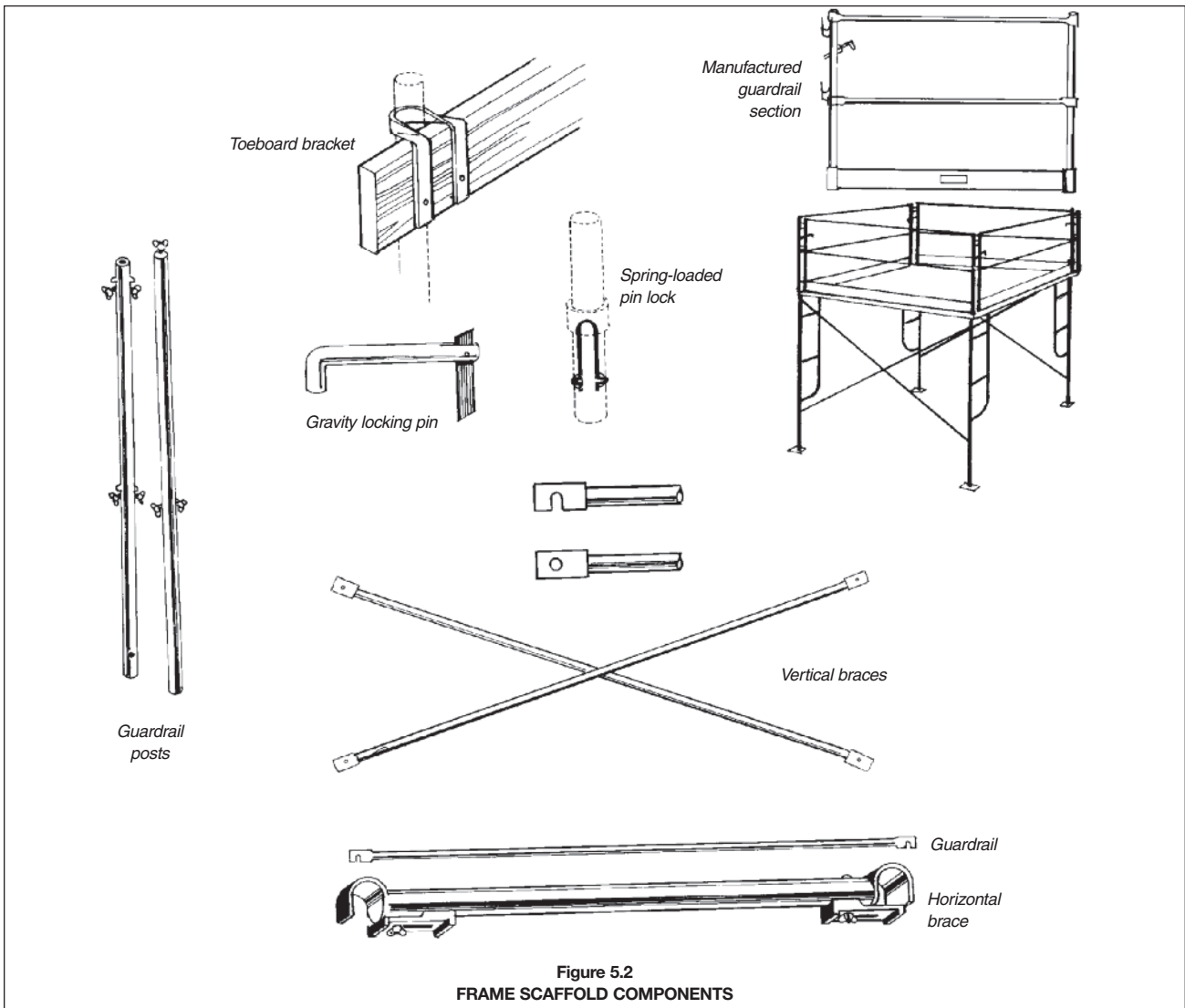
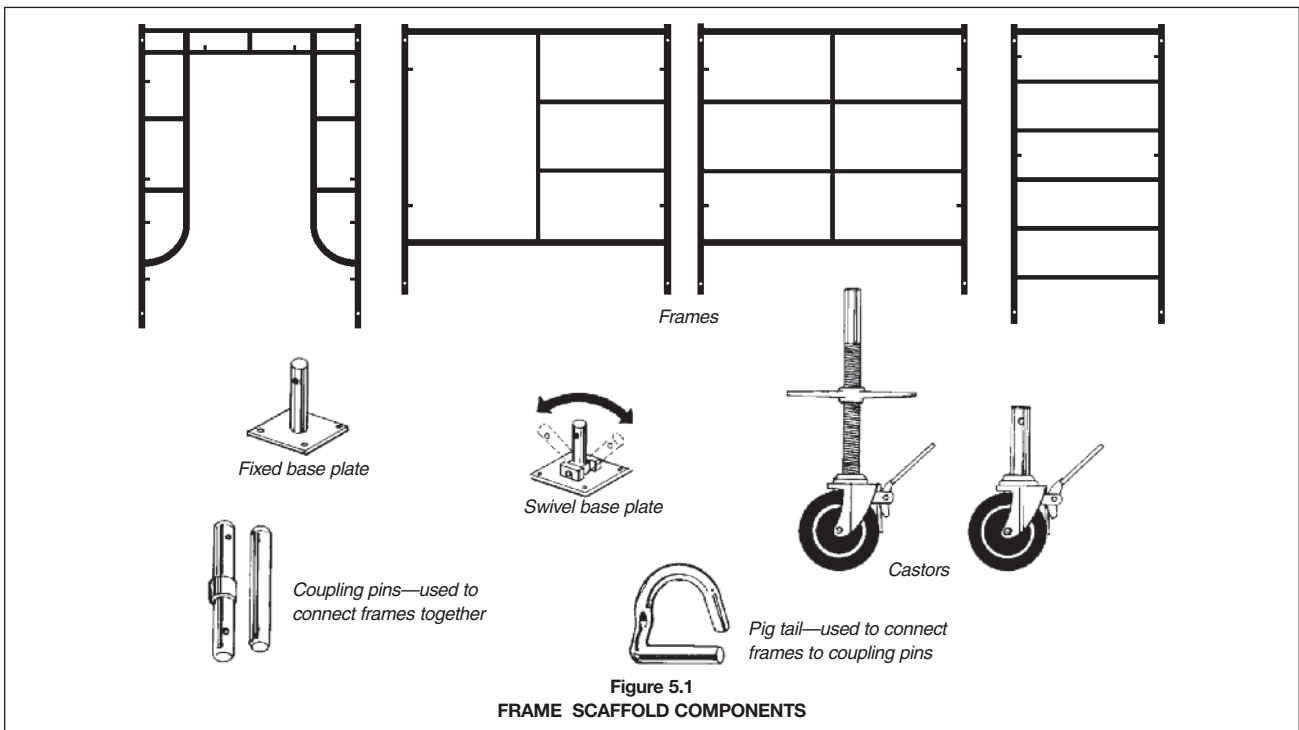
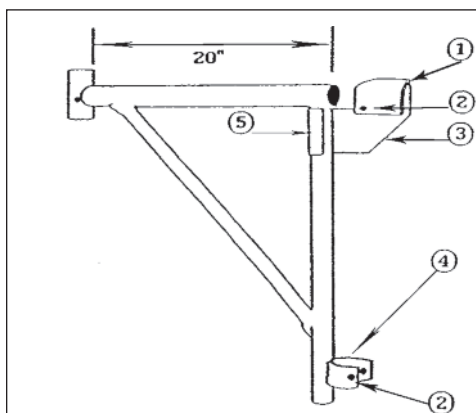

Figure 4.10  
TOWER SCAFFOLD





**Figure 5.3 - Outrigger / Side Bracket**

When purchasing outrigger/side brackets, look for the following features, numbered to correspond with Figure 5.3.

1. Hook tops out at a V-point to sit securely on varying diameters of horizontal frame members
2. Hook and bottom shoe are prepared to receive pin
3. Hook is heavy-gauge, fabricated from one piece of steel
4. Ensure that the lower shoe won't interfere with braces, locks, or other features of different manufacturer's frames
5. Hook plate is wrapped around vertical member and welded on three sides only

- frames are designed with “non-pinned” joints
- additional bracing is provided by a designed system using tube-and-clamp accessories
- horizontal braces on every third tier of frames
- platform materials to fully deck in the intended working level
- guardrails complete with toeboards
- guardrail posts where working platforms will be at the top level
- ladders or stairs for access
- intermediate platforms where required—not more than 9 metres (30 feet) apart and adjacent to vertical ladders.

**Tube-and-Clamp Scaffolds and Systems Scaffolds** have individual components unique to each type. These components are identified and discussed in detail in Section 6.

### 5.1 Platforms

Platforms for frame scaffolds are normally either aluminum/plywood platforms or wood planks. Planks normally come in 8-foot or 16-foot lengths to cover one or two 7-foot bays with adequate overhang. Platforms are dealt with in depth in Section 8.

### 5.2 Outrigger/Side Brackets

The use of outrigger brackets—also known as side brackets (Figure 5.3)—is very popular in the masonry industry. They are attached to the inside of the frame and accommodate a platform approximately 20" (two planks) wide. They provide a work platform for the mason at an ergonomically convenient location, lower than the material platform. Intended as a work platform only, they are not to be used for material storage.

Instances have been reported of brackets installed on the “wrong” side of the scaffold—facing the forklift, for example, to provide a landing area for skids of material. This is not acceptable because outrigger brackets are not designed for supporting material. Furthermore, the practice may lead to unbalanced loading of the scaffold, causing tip-over.

Figure 5.4 illustrates typical outrigger/side brackets attached to the scaffold for masonry use. For efficient, comfortable work, the brackets should be adjustable in lifts of no more than 600 mm (24 inches). A space no greater than 150 mm (6 inches) should be maintained between the bracket platform and the wall. Although the outrigger brackets illustrated are side brackets, end brackets are also available from most manufacturers.

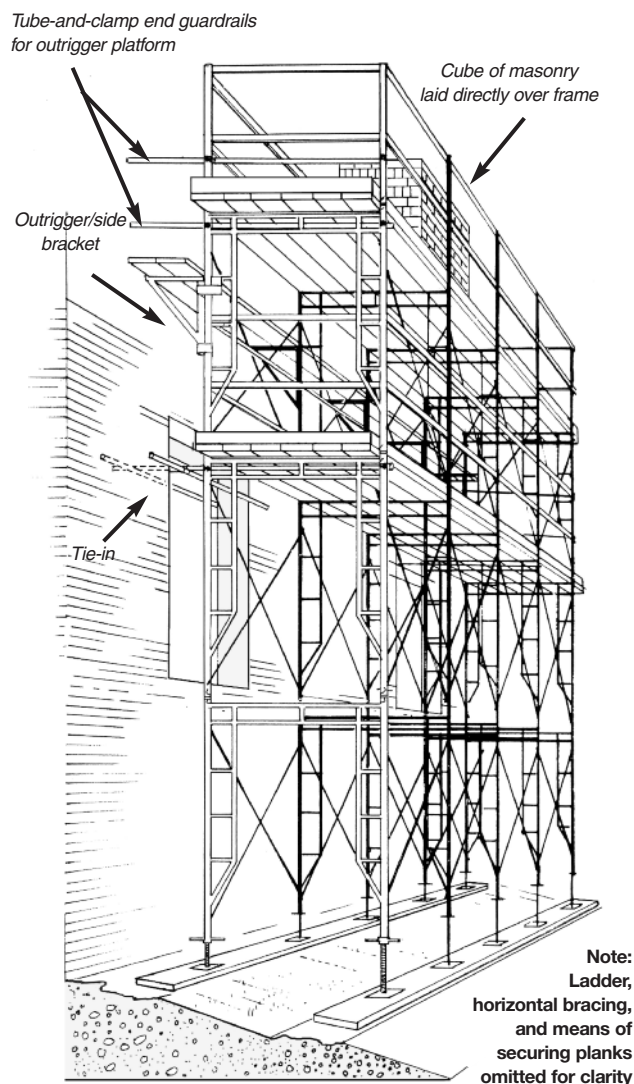

**Figure 5.4**  
**MASONRY SCAFFOLD WITH OUTRIGGER/SIDE BRACKETS**

Use the following good work practices:

- Do not drop or roughly handle outrigger/side brackets during erection or dismantling. This can bend or damage hooks.
- Use planks that are double-cleated at one end to ensure that the cleats are engaged over a bracket to prevent the bracket from pivoting.
- Inspect brackets as they are being installed on the scaffold to ensure that only sound brackets with no defects are used.

- Tag for repair any brackets that have deformed or cracked hooks, cracked welds, or other defects.
- Make sure that brackets are mounted securely on the frame all the way down.
- Never stock material on the bracket working platform. The working platform is for the worker only.
- Make sure that planks laid on the brackets extend at least 150 mm (6 inches) beyond the frames at either end.
- Place brackets so the level where the worker stands is no more than 1 metre (40 inches) below the level where the material is stored.

Beware of common hazards with outrigger/side brackets:

- hooks bent or deformed to the extent that they will roll off the frame under load
- hooks bent back into place, thereby causing cracks in the metal or welds which then break under load
- homemade brackets that are poorly designed and fabricated, too flimsy to bear the load, or not sized properly to hold two planks
- failure to inspect brackets during erection to ensure that they are not damaged
- failure to use planks that have double cleats on one end.

Other features to look for are

- manufacturer's plate showing name and model number
- brackets that are hot-dipped galvanized
- manufacturer's literature stating that the bracket has been designed and fabricated to meet loading requirements specified in the Ontario regulations and applicable CSA standards.

### 5.3 Ladders

Whether built into frames, attached as a separate component, or portable, ladders are an important means of access to scaffold platforms. We would substantially reduce the number of falls connected with climbing up and down scaffolds if workers always used adequate and properly erected ladders. Unfortunately, suitable ladders are not often provided or used.

A major problem with ladders built into the frame is that planks sometimes stick out so far that it's difficult to get from the ladder to the platform. This situation results in many injuries but can be overcome in one of three ways:

- use manufactured platform components which do not project beyond the support
- use a portable ladder where platform elevations are less than 9 metres (30 feet) in height (Figure 5.5)
- use a stand-off vertical ladder with a cage if the scaffold is above 3 metres (10 feet).

Ladder rails should extend at least 900 mm (3 feet) above the platform level to facilitate getting on and off. Injuries are often connected with stepping on and stepping off the ladder at the platform level.

Rest stations should be decked in on scaffold towers at intervals no greater than every 9 metres (30 feet). Climbing is strenuous work and accidents happen more frequently when climbers suffer from overexertion.

### 5.4 Guardrails

Failing to use guardrails is one of the main reasons for falls from scaffold platforms. Manufacturers of frame

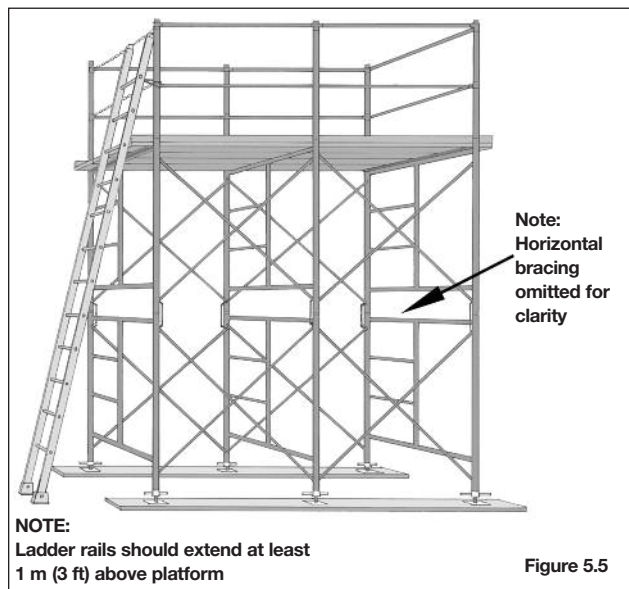

scaffolds have guardrail components which can be attached to the scaffold frames. These have posts that sit directly onto the connector pins and to which the rails are attached using wing nuts.

Where manufactured guardrails are not available, guardrails can be constructed from lumber (Figure 5.6) or tube-and-clamp components.

Tube-and-clamp guardrails may be constructed from standard aluminum scaffold tubing using parallel clamps to attach the vertical posts to each frame leg (Figure 5.6). Top rails and mid-rails should be attached to the vertical posts using right-angle clamps. Connections in these rails should be made with end-to-end clamps.

Most manufacturers have toeboard clips to fasten toeboards quickly and easily to standard tubular posts on either frames or guardrail posts.

A guardrail should consist of:

- a top rail about 1 metre (40 inches) above the platform
- a mid-rail about halfway between the platform and the top rail
- a toeboard at least 89 mm (3½") high at the platform level if made from wood, and
- posts no more than 2.4 metres (8 feet) apart if made from wood. Guardrail posts can be farther apart if the materials used are adequate to support the loads specified.

Guardrails should be designed to resist the forces specified in the Construction Regulation.

Frequently, guardrails must be removed to allow material to be placed on the scaffold platform. Workers must protect themselves from falling by using a fall-arrest system properly worn, used, and tied off. The fall-arrest system should be worn while the worker is removing the guardrail, receiving the material, and replacing the guardrail. Too often, guardrails are removed to receive materials and then not replaced. Many workers have fallen because other workers have left unguarded openings on scaffold platforms.

Figure 5.6  
GUARDRAILS

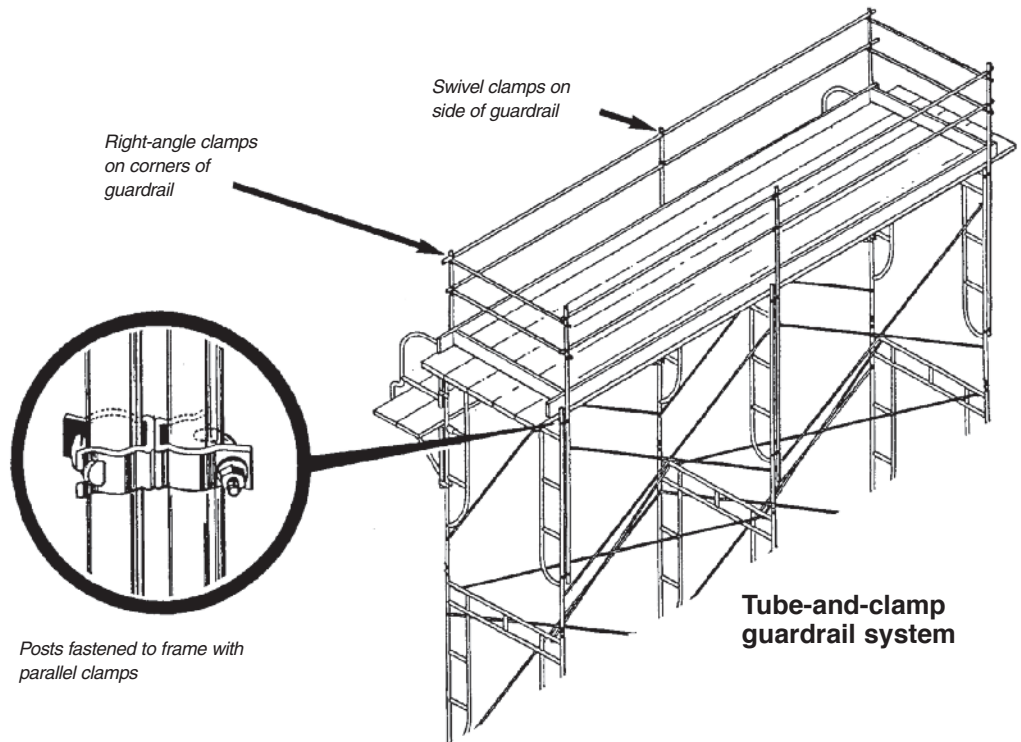
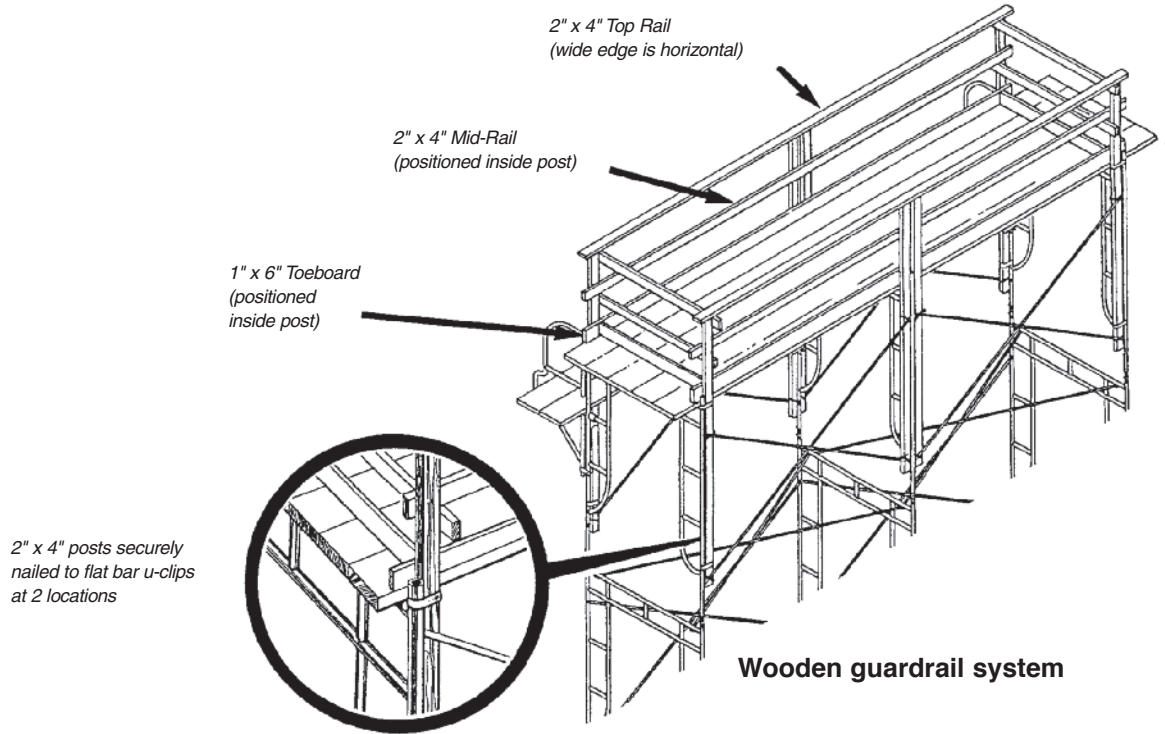

## 6 ERECTING AND DISMANTLING SCAFFOLDS

### 6.1 General

Scaffolds should always be erected under the supervision of a competent worker. Although scaffold systems vary between manufacturers, certain fundamental requirements are common to all scaffold systems. Frame scaffolds over 15 metres (50 feet) in height, and tube-and-clamp and systems scaffolds over 10 metres (33 feet), must be designed by a professional engineer. Supervisors must ensure that the scaffolds are constructed in accordance with that design.

#### 6.1.1 Foundations and Support Surfaces

Scaffolds must be erected on surfaces that can adequately support all loads applied by the scaffold. To support scaffolds, backfilled soils must be well compacted and levelled. Mud and soft soil should be replaced with compacted gravel or crushed stone. Embankments that appear unstable or susceptible to erosion by rain must be contained. Otherwise, the scaffold must be set far enough back to avoid settlement or failure of the embankment.

Where mudsills must be placed on sloping ground, levelling the area should be done, wherever possible, by excavating rather than backfilling (Figure 6.1).

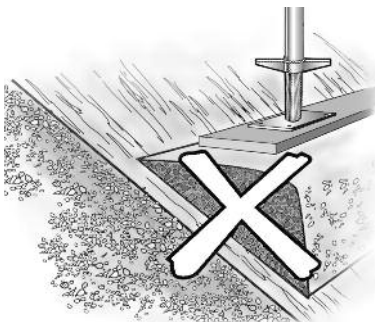

In some cases it may be necessary to use half-frames to accommodate grade changes. For these situations the side bracing is usually provided by using tube-and-clamp components.

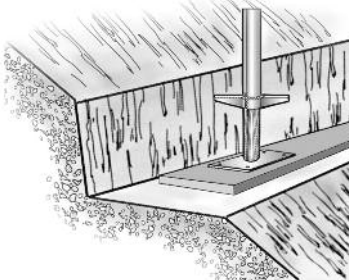

Figure 6.1  
MUDSILL ON SLOPING GROUND

Floors are usually adequate to support scaffold loads of workers, tools, and light materials. As loads become greater, floors, especially the older wooden types, should be examined to ensure that they will support the anticipated loads. In some cases, shoring below the floor and directly under the scaffold legs may be necessary. In other situations, you may need sills that span the floor support structure.

**Scaffolds erected on any type of soil should have a mudsill.** At minimum the mudsill should be a 48 mm x 248 mm (2" x 10") plank (full size) and should be continuous under at least two consecutive supports. The scaffold feet should rest centrally on the mudsill and the sill should, where possible, project at least 300 mm (1 foot) beyond the scaffold foot at the ends. Mudsills may be placed either along the length or across the width of the frames.

**Do not use blocking or packing such as bricks, short pieces of lumber, or other scrap materials either under scaffold feet or under mudsills (Figure 6.2).** If the scaffold is subjected to heavy loading, bricks or blocks can break. Vibration can cause blocking to move or shift, leaving a scaffold leg unsupported. In such conditions the scaffold can topple when heavy loads are applied.

Figure 6.2  
IMPROPER SUPPORT

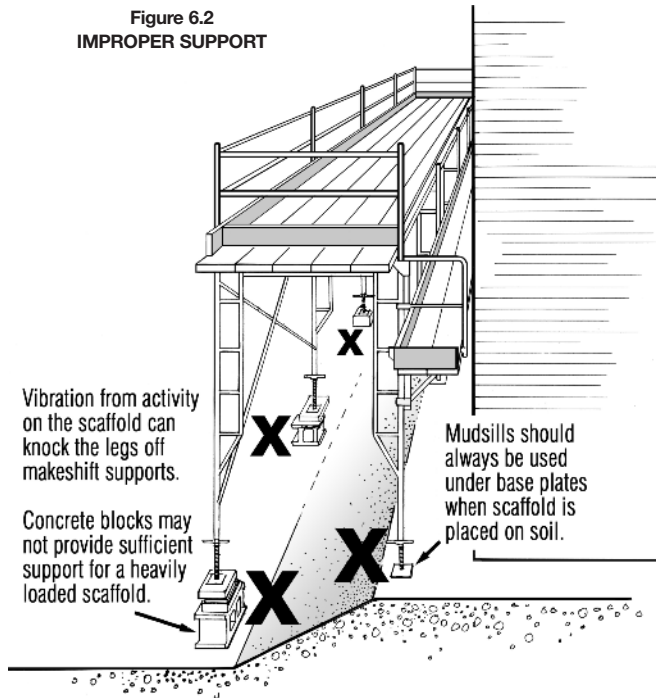

Take particular care when erecting scaffolds on frozen ground. Thawing soil is often water-soaked, resulting in considerable loss of bearing capacity. You must take thawing into account when tarps or other covers will be placed around a scaffold and the enclosure will be heated.

If the scaffold is inside a building, preparing the foundation may mean

- clearing away debris or construction materials and equipment stored in the way
- using sills or placing shoring under old wooden floors.

For a scaffold on the outside of a building, preparing the foundation may include

- replacing mud and soft ground with gravel or crushed stone
- levelling and compacting loose backfill
- stabilizing or protecting embankments
- providing protection against erosion from rain or thawing
- using mudsills.

Foundation preparation is important with any scaffold. It is especially important when scaffolds will be heavily loaded, as in masonry work. Differential settlement may damage scaffold components even if no serious incident or collapse occurs.

### 6.1.2 Inspection

Scaffold materials should be inspected before use for

- damage to structural components
- damage to hooks on manufactured platforms
- splits, knots, and dry rot in planks
- delamination in laminated veneer lumber planks
- presence of all necessary components for the job
- compatibility of components.

Structural components which are bent, damaged, or severely rusted should not be used. Similarly, platforms with damaged hooks should not be used until properly repaired. Planks showing damage should be discarded and removed from the site so that they cannot be used for platform material.

### 6.1.3 Location

Before erecting a scaffold, check the location for

- ground conditions
- overhead wires
- obstructions
- variation in surface elevation
- tie-in locations and methods.

Checking the location thoroughly beforehand will eliminate many of the problems that develop during erection and will allow erection to proceed smoothly, efficiently, and safely.

### 6.1.4 Base Plates

Base plates and adjustable screw jacks should be used whether the scaffold is outside on rough ground or indoors on a smooth level surface. Base plates should be centred on the width of the sill and nailed securely after the first tier has been erected. Sills may run either across the width or along the length of the scaffold depending on grade conditions and other factors. Generally, bearing capacity will be increased by running sills longitudinally because the sill has more contact with the ground.

### 6.1.5 Plumb

When the first tier of scaffold has been erected it should be checked for plumb, alignment, and level. Where necessary, adjustments can be made using the screw jacks.

Settlement or slight variations in the fit of the components may require additional adjustments as tiers are added to the scaffold tower. Braces should fit easily if the scaffold tower is level. If braces do not fit easily it is an indication that the scaffold is out of plumb or out of alignment.

### 6.1.6 Hoisting Materials

Where scaffolds will be more than three frames high, a well wheel or “gin” wheel and a hoist arm or davit will make the hoisting of materials easier during erection (Figure 6.3).

While materials can be pulled up by rope without these devices, the well wheel and hoist arm allow the hoisting to be done by workers on the ground. This is much safer and eliminates the risk of workers falling from the scaffold platform as they pull materials up by rope. Loads lifted by a well wheel should normally be no more than 50 kg (100 lb.) unless special structural provisions are made.

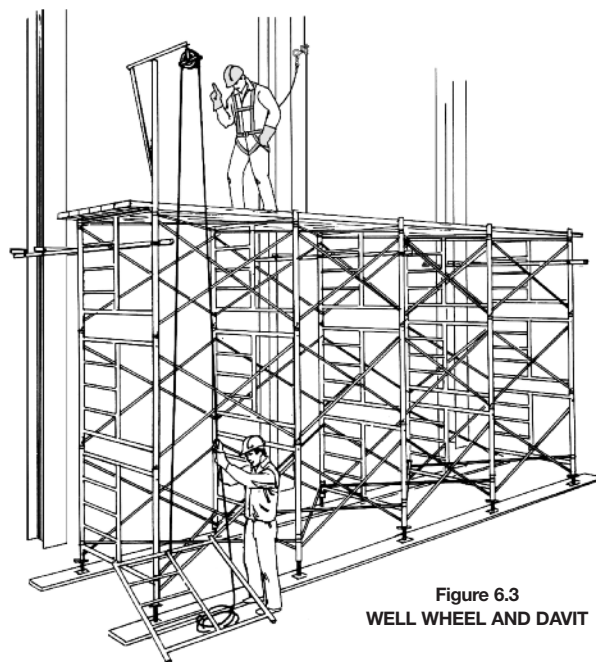

Figure 6.3  
WELL WHEEL AND DAVIT

The use of forklifts or other mechanical means of hoisting scaffold materials has become more common particularly in masonry applications. The use of this type of equipment greatly reduces the potential for overexertion injuries due to lifting and pulling. However, extra precaution must be taken to prevent powerline contact and other potential hazards such as overloading.

### 6.1.7 Tie-ins

Scaffolds must be tied in to a structure or otherwise stabilized—in accordance with manufacturer’s instructions and the Construction Regulation—as erection progresses. Leaving such items as tie-ins or positive connections until the scaffold is completely erected will not save time if it results in an accident or injury. Moreover, in most jurisdictions it is prohibited. For further information on tie-in requirements see Section 7.6.

### 6.1.8 Fall Protection in Scaffold Erection

Providing practical fall protection for workers erecting and dismantling scaffold and shoring has been challenging for the construction industry.

In Ontario, Section 26 of the Construction Regulation requires that workers erecting, using, or dismantling scaffolds must be protected from falling by using guardrails, travel restraint, fall-restricting systems, or fall-arrest systems.

For fall protection while workers are using a scaffold as a work platform, the safest solution is guardrails, provided they can be erected safely. Workers involved in erecting or dismantling scaffolds face a different challenge. Erecting guardrails and using fall-arrest equipment requires specialized procedures since normally there is nothing above the erector on which to anchor the fall protection system. For suggestions, see CSAO’s *Scaffolds and Frame Shoring Towers: Fall Protection*, which you can download from [www.csao.org](http://www.csao.org).

In all cases ensure that procedures comply with the regulations. You must use engineered design and procedures when required, and competent workers must review the installed scaffold before use. Pay special care and attention to anchorages.

A competent person must give adequate oral and written instructions to all workers using fall protection systems. Like all scaffolds, this equipment must be used under the supervision of a competent person.

## 6.2 ERECTING FRAME SCAFFOLDS

Frame scaffolds are the most common types of scaffolds used in Ontario. Too often they are erected by people who are inexperienced and do not know or recognize the potential hazards. Erectors must be aware of the potential dangers not only to themselves but also to the end user of the scaffold.

### 6.2.1 Fittings and Accessories

People are sometimes reluctant to install all the parts, fittings, and accessories required for a properly built frame scaffold. This poor practice continues because parts are frequently lost or otherwise not available at the site. Other times, it is due to haste, lack of training, or carelessness.

Always use base plates with adjustable screw jacks. They allow for minor adjustments to keep the scaffold plumb and level. Base plates usually have holes so you can nail them to mudsills. This is good practice and should be done as soon as the first tier is erected and plumbed with base plates centred on the sills.

You must brace in the vertical plane on both sides of every frame. Bracing in the horizontal plane should be done at the joint of every third tier of frames starting with the first tier. Horizontal bracing should coincide with the point at which the scaffold is tied to the building. Horizontal bracing is needed to maintain scaffold stability and full load-carrying capacity. The use of horizontal bracing on the first tier helps to square up the scaffold before nailing base plates to mudsills.

Every scaffold manufacturer provides coupling devices to connect scaffold frames together vertically. Figure 6.4 illustrates various types. Erectors often ignore these devices, believing that the bearing weight of the scaffold and its load will keep the frame above firmly connected to the frame below. This will probably hold true until the scaffold moves or sways. Then the joint may pull apart, causing a scaffold collapse. Coupling devices should always be used and installed properly on every leg of the scaffold, at every joint, as assembly proceeds.

If wheels or castors are used they should be securely attached to the scaffold and be equipped with brakes. Failure to attach wheels or castors properly to the frame has been the cause of many serious accidents and fatalities involving rolling scaffolds. Wheels or castors must have brakes which are well maintained and easily applied.

Scaffolds should always have guardrails. Unfortunately, people frequently leave them out, especially on scaffolds of low to moderate height. Workers have been seriously injured as a result.

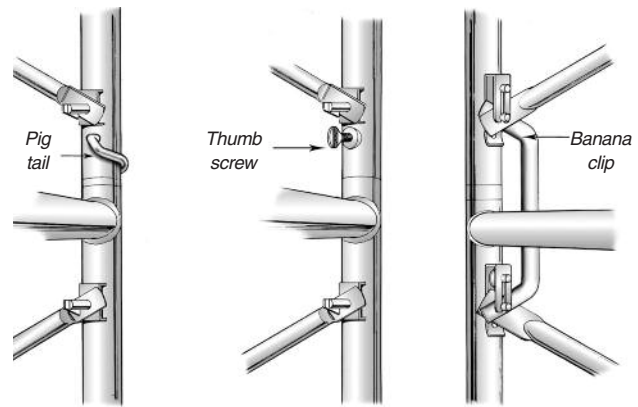

Figure 6.4  
COUPLING DEVICES

### 6.2.2 Braces

Once you have fitted the adjustable base plates on the frames you must then attach the braces for each tower span. The braces should slide into place easily. If force is required, either the braces are bent or damaged or the frames are out of plumb or alignment.

Secure braces at each end. The erection crew must ensure that self-locking devices move freely and have fallen into place. Rust or slight damage can prevent some of these devices from working properly and they then require force to secure them in position. Maintain moving parts in good condition to prevent this situation from developing.

### 6.2.3 Platform Erection

Ensure that parts and fittings are in place and secure before placing platform components on a scaffold tier.

When proceeding with the next tier, workers should use platform sections or planks from the previous tier, leaving behind either one platform section or two planks. While this requires more material it speeds up erection because workers have platforms to stand on when erecting or dismantling the platform above. At heights above 3 metres (10 feet), all workers involved in the erection or dismantling of scaffolds must be protected by a guardrail or by other means of fall protection.

Frequently, low scaffolds one or two frames in height are not fully decked in. This can lead to accidents and serious injury. Many lost-time injuries occur each year in Ontario because platforms are inadequately decked.

### 6.2.4 Ladders

Where frames are not equipped with ladder rungs, ladders should be installed as the erection of each tier proceeds. Injuries involving scaffolds frequently occur when workers are climbing up or down the scaffold. Providing proper ladders will help prevent such injuries. See Section 5.3 for more information on ladders.

### 6.2.5 Guardrails

Guardrails must be installed at each working level as the scaffold is erected and also at the top level of the scaffold. This is recommended for all scaffolds regardless of height. Although you do not require guardrails until scaffolds are 2.4 metres (8 feet) high, a considerable number of severe injuries and even fatalities are due to falls from lower scaffolds.

Some manufacturers have recently introduced temporary guardrails workers can use when erecting scaffolds. A guardrail can be set in position from the previous level and can provide a protected work platform for the worker to install the next level of components. Each type of guardrail has a unique design and system of attachment to the scaffold.

Figure 6.5 shows one example of an “advanced guardrail” with the platform fully enclosed. The guardrail is positioned on a bracket which is mounted from below on the outside of the scaffold, and does not interfere with the placement of subsequent frames and braces. As the scaffold goes up the guardrail may be raised as well, or left in position to form the permanent guardrail. The erector must use another fall protection method—permanent guardrails or a full body harness with a lanyard attached to the scaffold—while moving either the platforms or the temporary guardrail.

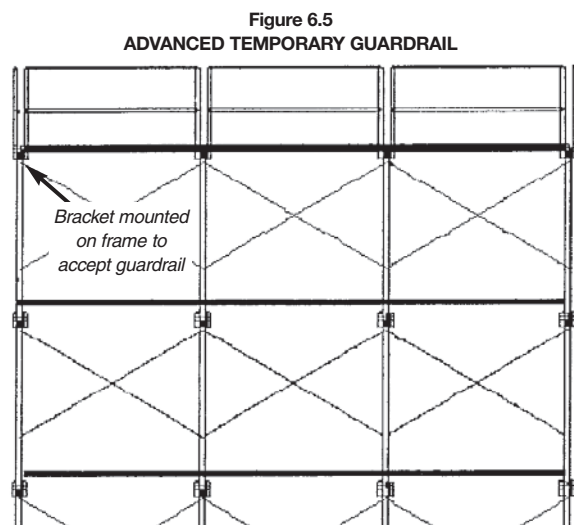

### 6.3 ERECTING TUBE-and-CLAMP SCAFFOLDS

Most of the general rules that apply to frame scaffolding also apply to tube-and-clamp scaffolding. The requirements for mudsills, platforms, and guardrails are exactly the same for both types.

The most important difference between the two is the additional degree of skill and knowledge necessary to erect tube-and-clamp scaffolds safely and efficiently. Tube-and-clamp scaffolds should not be erected by an unskilled or inexperienced crew. Basic terms are identified in Figure 6.6.

#### 6.3.1 General Requirements

Tube-and-clamp scaffolds are erected plumb and level like frame scaffolds but the erection system is quite different.

The scaffold must start with a set of ledgers and transoms immediately above the base plates. This is necessary to hold the base plates in their proper position. The typical erection sequence for a simple tower is shown in Figure 6.6. Each vertical and horizontal member should be checked with a spirit level as erection proceeds.

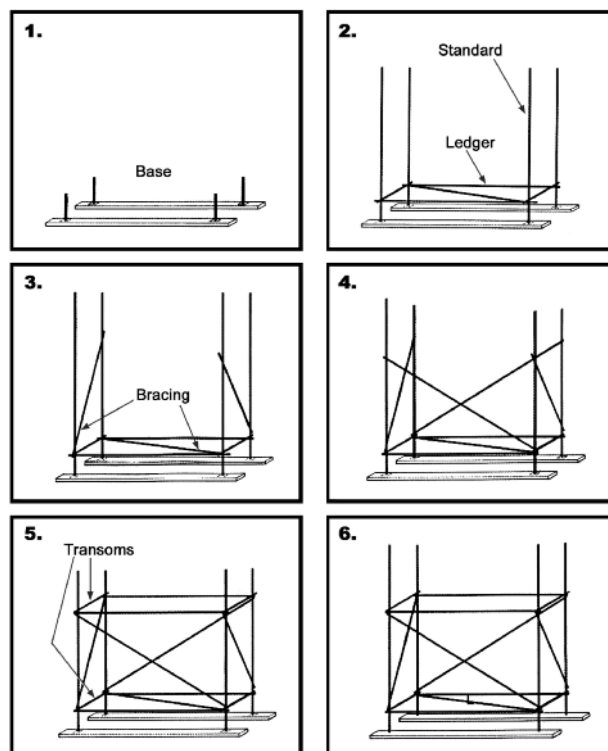

Figure 6.6  
ERECTION OF TUBE-AND-CLAMP SCAFFOLD

#### 6.3.2 Materials and Components

The tubing normally used for tube-and-clamp scaffolding in Ontario is schedule 40, 1.9” OD (1½” ID) aluminum pipe manufactured of either 6061 or 6063 alloys.

Clamps are usually made of steel and have a variety of configurations. Depending on the manufacturer, clamps can be fastened using wedges, bolts, or other methods. The following types are used.

- **Right-Angle Clamp**—a clamp used for connecting tubes at right angles. They maintain the right-angled orientation providing rigidity to the structure.
- **End-to-End Clamp**—an externally applied clamp to connect two tubes end-to-end.
- **Swivel Clamp**—a clamp used to connect two tubes when right-angle clamps cannot be used. They usually connect bracing.
- **Parallel Clamp**—a clamp used for lap jointing two tubes together. It can be used to connect short guardrail posts to the standards or legs of frame scaffolds.
- **Concrete Tie Clamp**—a clamp used to connect a tube to concrete or other surfaces using a bolt or concrete anchor.

These and other devices are shown in Figure 6.8 depicting a typical tube-and-clamp scaffold.

Before using clamps, check them carefully for damage to wedges or threads on bolts and distortion of the clamp body.

### 6.3.3 Spacing of Standards

The spacing of standards depends on the load-carrying requirements of the scaffold. Wherever possible, tube-and-clamp scaffolding should have bay and elevation spacing of about 2 metres (6'-6") longitudinally and vertically. This allows for the front sway bracing to be located at approximately 45° to the horizontal. It also facilitates the use of 5-metre (16-foot) planks with adequate overhang. The width of these platforms can vary but is usually approximately 1 metre (3 feet). This spacing allows the aluminum tubing specified earlier to carry normal construction loads adequately. An advantage of tube-and-clamp scaffolding is that the platform height can be easily adjusted to the most appropriate level for the work being done.

### 6.3.4 Ledgers and Transoms

Ledgers should be connected to standards using right-angle clamps. These clamps maintain a rigid 90° angle between members.

Transoms should be placed above the ledgers and both should be maintained in a horizontal position by levelling with a spirit level. Transoms may be connected to either standards or ledgers by using right-angle clamps.

### 6.3.5 Joints in Standards and Ledgers

Joints in standards and ledgers should be made with end-to-end clamps. These joints should be as close to the node points as the clamp arrangements will allow. Joints in vertically-adjacent ledgers should not occur in the same bay but should be staggered to provide rigidity.

A node point is the point at which the ledger-to-standard, transom-to-standard, and bracing-to-standard connections come together. An example of a node point is shown in Figure 4.7 and below.

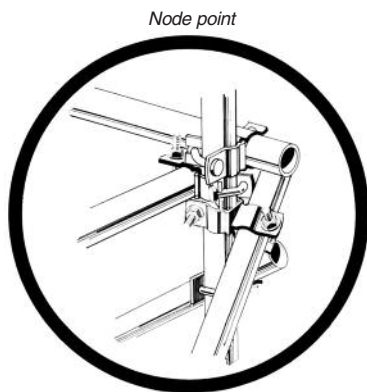

### 6.3.6 Intermediate Transoms

You should install intermediate transoms when the scaffold will be supporting heavy loads. You can also use them to avoid lapping planks and the tripping hazard that comes with it.

### 6.3.7 Tie-ins

Tie-ins are required with tube-and-clamp scaffolding. They should be located at every second node vertically and

every third standard horizontally. The tie-in tube should be connected to both standards or both ledgers, near the standard to provide rigidity. Connections should be made with right-angle clamps. Tie-ins should be capable of withstanding both tension (pull) and compression (push) forces (Figure 6.8).

### 6.3.8 Bracing

Internal bracing (Figure 6.8) is connected standard-to-standard using swivel clamps. It should be clamped as close to the node as possible. Internal bracing should normally be placed at every third standard. The location should coincide with tie-in points. You should also install bracing for tube-and-clamp scaffolding as erection progresses.

Face sway bracing should be installed to the full height of the scaffold. It may be located in a single bay or extend across several bays (Figure 6.7). Where the bracing is located in single bays it should be in the end bays and at least in every fourth bay longitudinally. In practice, it becomes difficult to get bracing close enough to the node points if it extends more than four bays in width (see ends of bracing in Figure 6.7).

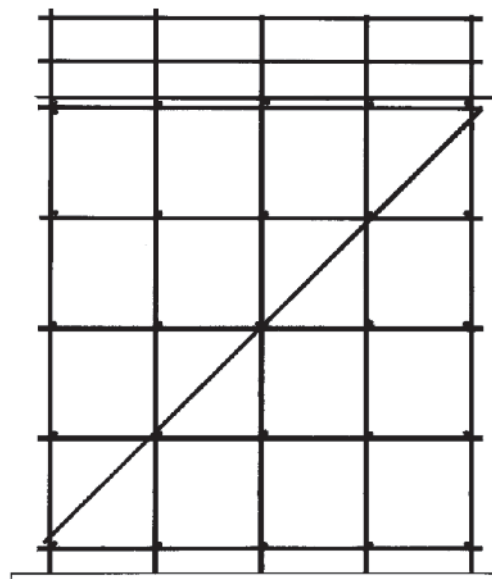
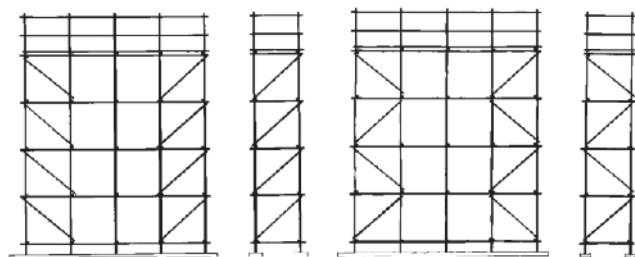
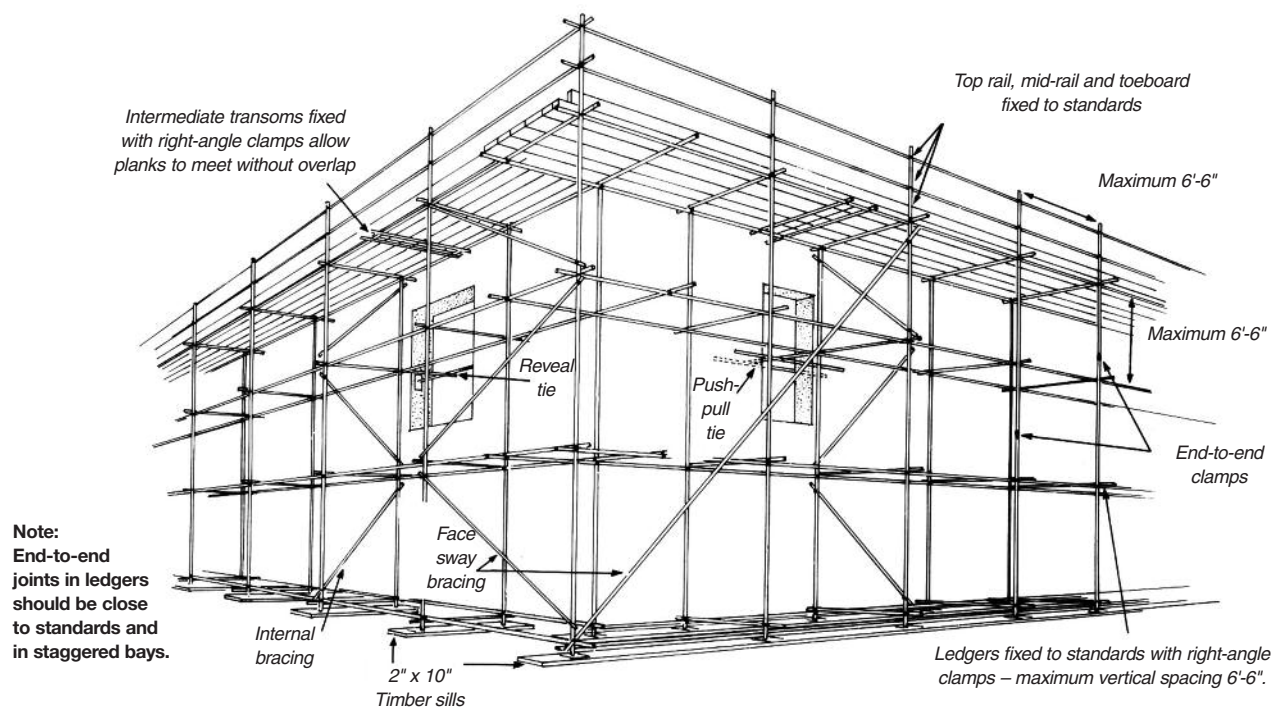
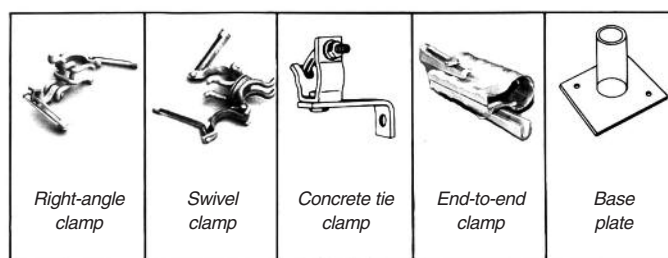

Figure 6.7  
TUBE-AND-CLAMP BRACING

### 6.3.9 Drawings and Inspections

We strongly recommend that a sketch or drawing be prepared before erecting tube-and-clamp scaffolding. It is important that you place the standard to accommodate the anticipated loads adequately. Bracing must also be designed to provide stability and to transfer horizontal loads to tie-in points.

Figure 6.8  
COMPLETED TUBE-AND-CLAMP SCAFFOLD



Where the platform will be more than 10 metres (33 feet) high or where unusual structures such as cantilevered platforms are involved, a professional engineer must design the scaffold. A professional engineer or a competent worker must inspect the scaffold before it is used to ensure that it is erected in accordance with the design drawings.

#### 6.4 ERECTION of SYSTEMS SCAFFOLDS

Erection of systems scaffold is very similar to that of tube-and-clamp scaffold. The requirements for mudsills, platforms, and guardrails are the same as is the requirement for being built level and plumb. The main differences are the method of connecting individual members together and the fact that all the members are of a fixed length. As with tube-and-clamp scaffolds, all systems scaffolds above 10 metres (33 feet) must be designed by a professional engineer.

##### 6.4.1 Components

Standards come in a variety of lengths and have a variety of built-in connection points at equal distances along their length. These connectors are normally between 450 and 500 mm (18 and 21 inches) apart depending on the

manufacturer. Typical connections are shown in Figure 6.9, although others are available. An end-to-end connection, normally a spigot, is formed at one end to facilitate extension of the standard.

**Starter Collars** are short standards with one set of system rings or rosettes attached. They are convenient to use because they allow one person to put the first set of transoms and ledgers in place easily (Figure 6.10).

**Ledgers or Runners** for each system are available in varying lengths and have built-in connection devices for connecting to the standards. The connection is secured by wedging, bolting, or by other methods.

**Transoms or Bearers** are made wide enough for four or five planks. They normally have end connections similar to those of ledgers and connect directly to the standard. Normally transoms have a lip or groove—particular to the individual manufacturer—designed to accommodate the platform.

**Braces** are made in set lengths to fit the scaffold being constructed, with connections at both ends to fit directly onto the connection point on the standard.

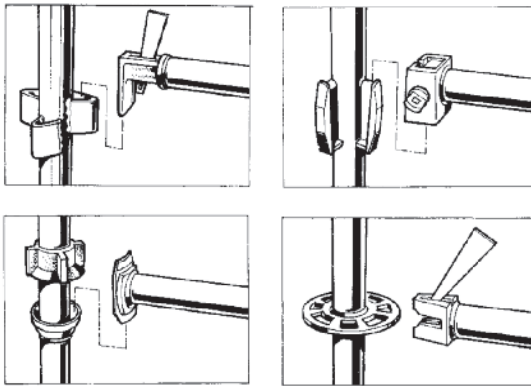

Figure 6.9  
TYPICAL SYSTEMS SCAFFOLD CONNECTORS

**Platform boards** (also called staging) come in a variety of lengths and widths. They fit directly into the transoms and can be secured to prevent wind uplift. To facilitate climbing, some platforms have trap doors with built-in drop-down ladders.

### 6.4.2 Erection Procedure

The foundation for systems scaffolds should be prepared in the same way as other types of scaffolding, ensuring a firm level base, and using mudsills, base plates, and adjustable screw jacks.

The base plates should be laid out in what you estimate is the correct location. We recommend starter collars since they allow scaffolds to be laid out level and square.

The first level of transoms and ledgers should be placed on the starter collars and be levelled using the screw jacks.

When the scaffold is square and level you should tighten the connections and nail the base plates to the mudsills.

At this point set up an erection platform for installing the standards for the next lift. You now install the second level ledgers and transoms as well as the deck.

You must install ledger bracing at the ends of all system scaffolds and at intervals according to the manufacturers' recommendations. Each brace will be the correct length for the span being braced and should be connected to the attachment point on the standard.

You must install face or sway bracing according to manufacturers' instructions. Again, attachment points are set on the standards, and the braces come in specific lengths for the span of the scaffold being constructed. Normally, every third bay is braced for sway.

Figure 6.10 outlines the typical erection procedure for systems scaffold.

### 6.4.3 Tie-ins

Systems scaffolds must be tied in to structures using the 3-to-1 rule as with other scaffolds. Some manufacturers have special adjustable ties which connect directly into the standards, while others use a tube-and-clamp method to tie in to the structure. Anchors attached to the structure are the same as in frame or tube-and-clamp scaffolds.

### 6.4.4 Guardrails

Generally, guardrails are installed at all working levels. These guardrail components come in modular lengths and are made from lighter materials than the ledgers. They attach directly to the connection points on the standards.

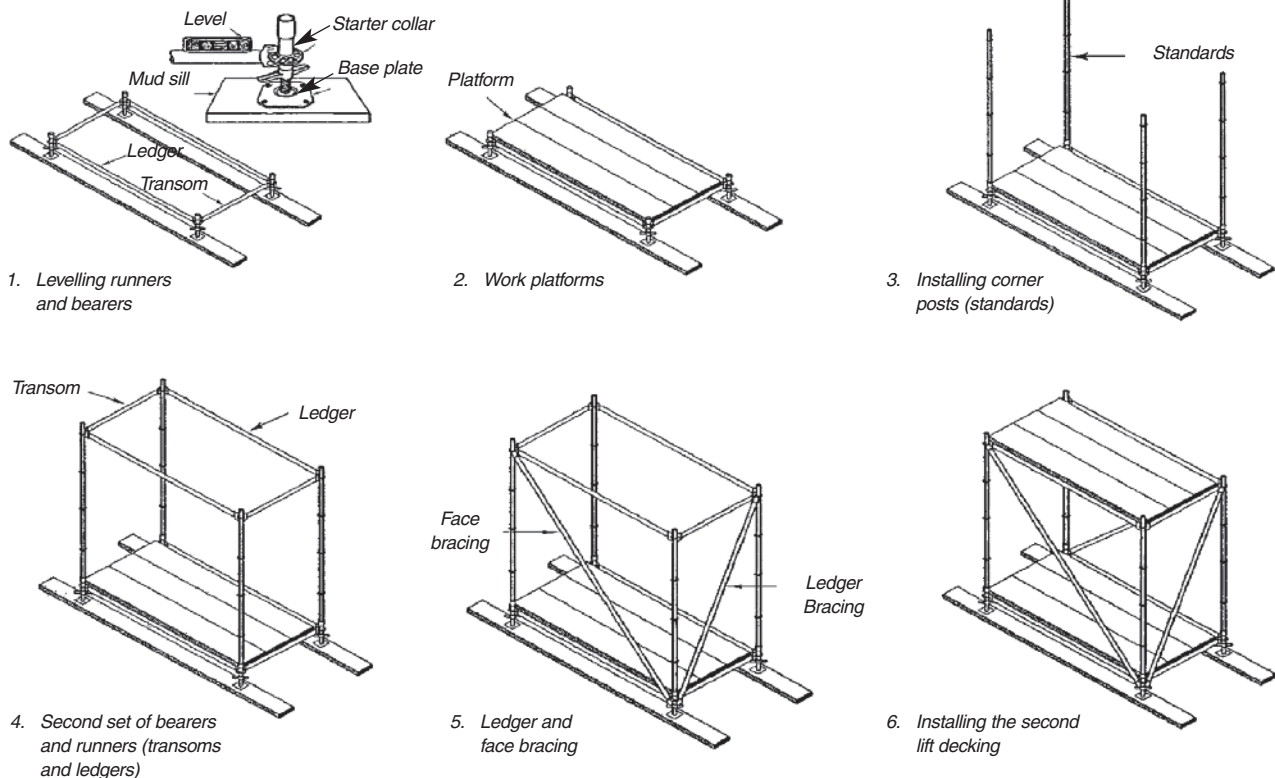

Figure 6.10  
ERECTION SEQUENCE OF TYPICAL SYSTEMS SCAFFOLD

Certain manufacturers have developed advanced guardrail systems that can be installed for a level above the erector, providing fall protection for the worker accessing the next level.

The example shown in Figure 6.11 consists of a “T” shaped temporary guardrail which is attached to the permanent guardrails on the level underneath. When mounted, it extends the required distance past the deck above to form a guardrail. The erector can then work safely without being tied off and install the next level of standards, ledgers, and transoms.

## 6.5 DISMANTLING

Dismantling frame scaffolds is essentially erection in reverse. Each tier should be completely dismantled and the material lowered to the ground before beginning to dismantle the next tier.

If platform sections or planks have been left at each level during erection, as suggested above, it should be relatively easy to lower platform materials from above and deck in the current working platform completely. Extra platform material can be lowered to the ground. Using this procedure, workers will be operating most of the time from a fully decked-in platform. This makes for easier removal of braces and frames.

Dismantled materials should be lowered using a well wheel and hoist arm or by mechanical means. Dropping materials not only causes damage and waste, but also endangers workers below—and is illegal in most jurisdictions.

When scaffolds have been in the same location for a long time, pins and other components frequently rust, braces become bent, and materials such as mortar or paint often build up on the scaffold parts. All of these can prevent components from separating easily. Removing jammed or rusted scaffold components can be very hazardous. Tugging or pulling on stuck components can cause you to lose your balance and fall. Workers should wear a full body harness and lanyard tied off to a scaffold frame or lifeline before attempting to loosen stuck or jammed parts.

Dismantling tube-and-clamp and systems scaffolding must proceed in reverse order to erection.

Each tier should be completely dismantled as far as connections will allow before you begin dismantling the lower tier. You must dismantle them this way because the bracing for tube-and-clamp scaffold is not located in each bay as it is for frame scaffolding. The span or spans with front sway bracing should be the last to be dismantled on each tier.

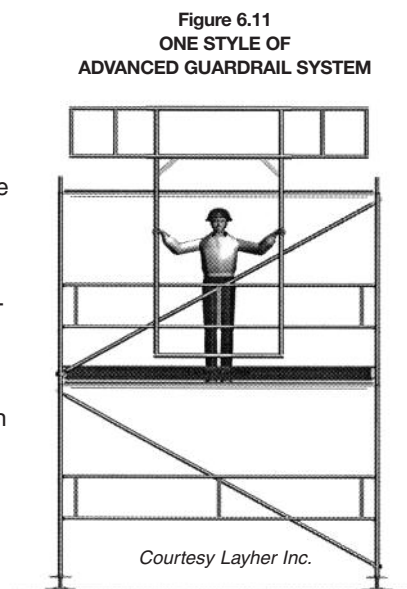

## 7 SCAFFOLD STABILITY

### 7.1 Three-to-One Rule

The ratio of height to least lateral dimension must not exceed 3 to 1 unless the scaffold is

- tied to a structure, as discussed in Section 7.6
- equipped with outrigger stabilizers (Figure 7.1) to maintain the ratio of 3 to 1
- equipped with suitable guy wires.

### 7.2 Outrigger Stabilizers

Scaffold manufacturers usually make outrigger stabilizers that can be attached to their equipment (Figure 7.1).

**Figure 7.1**  
**OUTRIGGER STABILIZERS**

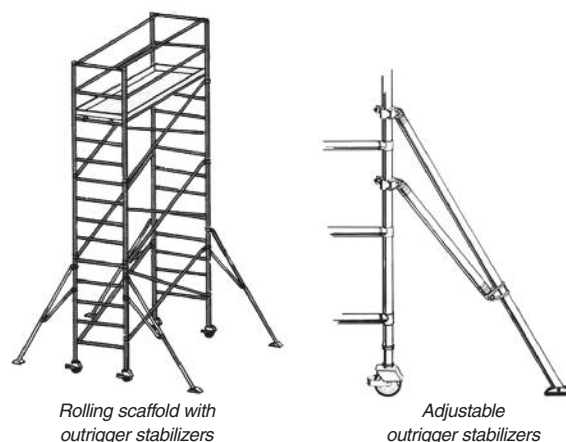

With devices of this type, ensure that the outrigger is adjusted so that vibration or dynamic loads on the platform will not move the stabilizer. Where stabilizers with castors are used the castors must rest firmly on a solid surface, with the brakes applied, and with the stabilizer secured in the extended position before workers use the platform (Figure 7.2). Many of these stabilizers fold up to allow movement through smaller openings and around obstructions (Figure 7.2).

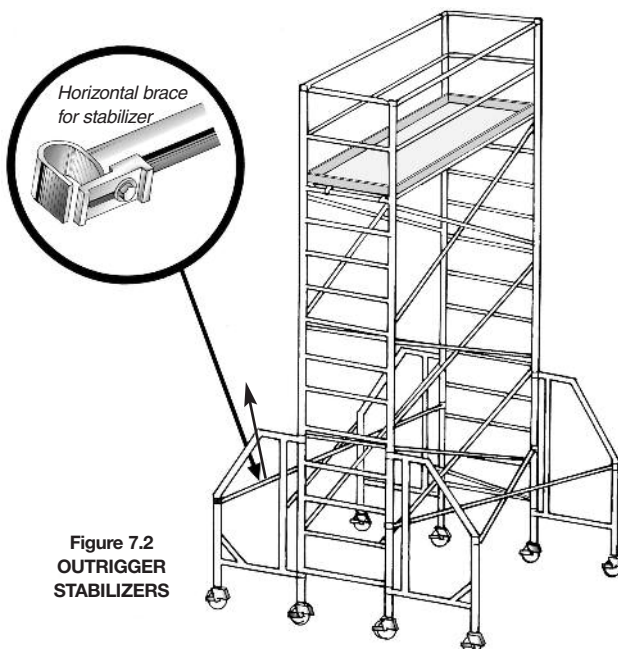

### 7.3 Limitations to the Three-to-One Rule

The 3-to-1 rule applies only to the extent that outriggers are extended symmetrically about the scaffold tower. If the outriggers are extended only on one side, you prevent toppling only in that direction.

### 7.4 Damage

Most bracing systems for tubular frame scaffolds are manufactured from light materials and are easily damaged.

**Do not use braces with kinks, bends, or deformations.** Such damage can weaken them significantly. The ends of braces are frequently damaged by dropping them on concrete or other hard surfaces during dismantling. Ends of braces are also frequently bent by forcing them onto the locking pin during erection. Constant bending can cause the ends to crack. You should inspect them before use and discard braces with cracked ends. You should maintain the locking device onto which the brace fits in good condition. It should move freely to accept and release the brace. Common securing devices are shown in Figure 7.3.

Figure 7.3  
SECURING DEVICES FOR FRAME SCAFFOLD BRACES

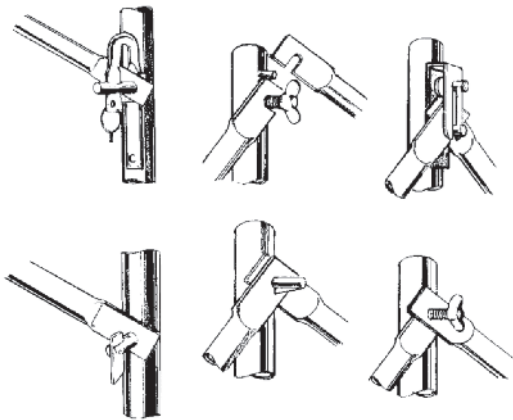

### 7.5 Installation Problems and Symptoms

Ensure that bracing is secured in place. Otherwise, scaffold movement can dislodge the braces and reduce the stability of the scaffold. These devices must secure the braces in place but they must operate freely so that it is easy to erect and dismantle the scaffold. Many times a worker has lost balance and fallen when trying to release a jammed or rusted drop hook while dismantling a scaffold.

You should completely deck platforms used to install bracing. Trying to work from a platform one or two planks wide often results in a fall. In addition, it leads to greater damage to the ends of scaffold braces because they bend when they are not kept close to proper alignment during installation and removal.

If a brace does not easily drop onto pins something is wrong. The brace may simply be bent and should be discarded. Often, however, it means the scaffold is twisted and out of plumb. Braces should not be forced or hammered onto the pin. The condition causing this difficulty should be corrected so that the brace slides onto the pin easily. Adjusting screw jacks slightly will often solve this problem. However, you need to take care to ensure the scaffold is not adjusted out of plumb.

### 7.6 Tie-in Requirements

Scaffolds which exceed the 3-to-1 rule of height to least lateral dimension must be tied in to a building or structure. Tie-ins should be applied at every third frame vertically second frame horizontally for tubular frame scaffolds. Tie-ins for tube-and-clamp scaffolds should be applied at every second node vertically and every third standard horizontally.

These tie-ins must be capable of sustaining lateral loads in both tension (pull) and compression (push). Examples are shown in Figure 7.4.

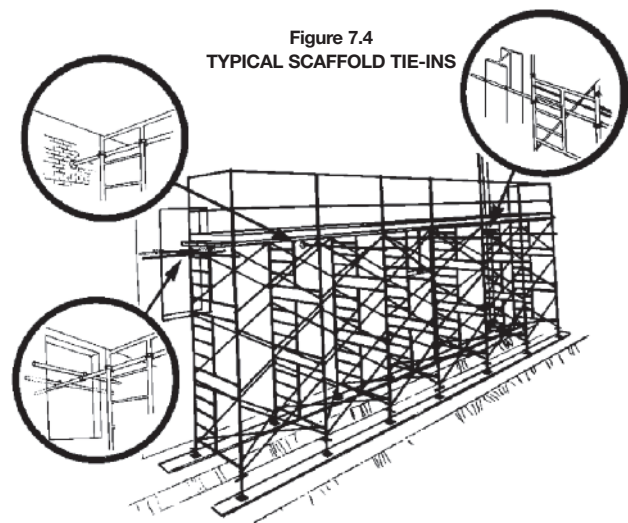

Wind loads can affect tie-ins and bracing. These loads vary not only with speed but also with the exposure of the location and the height and shape of structures where the scaffold is erected. In addition, scaffolds which are going to be enclosed for winter construction or sandblasting will be subjected to significantly greater wind loads. If severe winds are expected it is recommended that a professional engineer be consulted for tie-in requirements.

## 8 PLATFORMS

Before you select the platform material, you need to assess the weight of the workers, tools, and materials to be supported. You must also take into consideration the spans being used in the scaffold.

### 8.1 Typical Loads and Requirements

Minimum platform capacities vary from jurisdiction to jurisdiction. In Ontario, the minimum platform capacity is a uniformly distributed load of 2.4 kN/m<sup>2</sup> (50 lb./sq. ft.) for construction-related work. This is usually sufficient for workers, their tools and equipment, as well as a moderate amount of light materials. It is not sufficient for heavy loads such as those used in masonry construction.

For masonry construction where the scaffold will support large pallets of concrete blocks, minimum capacity should be at least a uniformly distributed load of 7.2 kN/m<sup>2</sup> (150 lb./sq. ft.). This means that scaffolds with spans of 2.1 metres (7 feet) should be at least double-planked. Aluminum/plywood platforms should also have a layer of scaffold planks on top.

Table 8.1

**Maximum loads on planks for scaffold platforms 5 feet in width**

5'-0"

7'-0"

Layers of Planks	5'-0"			7'-0"		
	—	≡	≡≡	—	≡	≡≡
UNIFORM LOAD PER SQUARE FOOT	150 lbs.	No. 1			No. 1	
	100 lbs.	No. 1			SEL STR	No. 1
	75 lbs.	No. 1			No. 1	
	50 lbs.	No. 1			No. 1	
4'X4' PALLET LOADS (POUNDS)	4000	SEL STR	No. 1		SEL STR	No. 1
	2900	No. 1			No. 1	
	2430	No. 1			SEL STR	No. 1
	1760	No. 1			No. 1	
	1520	No. 1			No. 1	

**Notes**

- Planks are **spruce-pine-fir species group (SPF)**.
- Planks are at least 1<sup>7</sup>/<sub>8</sub>" thick and at least 9<sup>3</sup>/<sub>4</sub>" wide.
- Grade is either number one (No. 1) or select structural (SEL STR).
- Allowable stresses conform with CSA Standard CAN3-086-1984 "Engineering Design in Wood."
- No stress increases are included for load sharing or load duration.
- Scaffold platforms are 5' wide and fully decked in.
- Loads indicated are **maximum** for grade and loading conditions. Shaded areas indicate that **no** SPF grades are capable of carrying the loads.

For weights of construction materials and allowable load-carrying capacities of planks at various spans, consult Table 8.1 and Table 9.1.

**8.2 Aluminum/Plywood Platform Panels**

Most manufacturers make their heavy-duty platforms capable of supporting a uniformly distributed load of 3.6 kn/m<sup>2</sup> (75 lb./sq. ft.) together with a concentrated load of 227 kg (500 lb.) spread over an area near the centre of the span. The load-carrying capacity of these platforms varies to some extent.

It is recommended that the rated load-carrying capacity be obtained from the supplier and marked on the platform panel if the manufacturer has not provided such information on the equipment already. The light-duty platforms available with much less capacity are not suitable for construction.

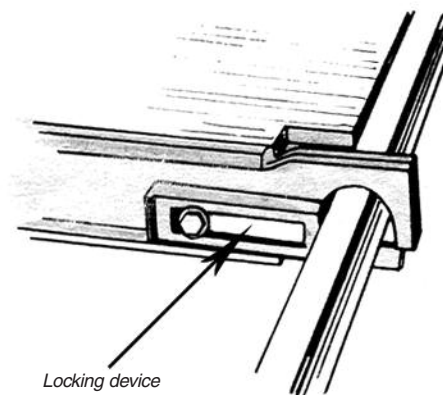

Figure 8.1  
SECURING ALUMINUM/PLYWOOD PLATFORMS

The advantage of aluminum/plywood platform panels is that they are light and durable. Worn-out plywood can easily be replaced. However, they are expensive and the hooks on most models can be damaged if dropped from the scaffold repeatedly during dismantling. Check the platform hooks and fastening hardware regularly for looseness, cracking, and distortion. When used outdoors, these platforms should be secured to the scaffold frames using wind locks. Otherwise, when left unloaded, they can be blown off the scaffold by strong winds.

### 8.3 Laminated Veneer Lumber

This material is really a special type of exterior plywood with laminations oriented longitudinally rather than in two directions. The wood is usually spruce or Douglas fir, although other structural species can be used. The material is manufactured in large sheets of various thicknesses that can be sawn to the sizes required.

The use of laminated veneer lumber as a scaffold platform material is increasing. The strength varies from manufacturer to manufacturer depending on method of fabrication and species of wood used. Users of the material should ask suppliers to furnish rated working loads for the scaffold spans on which the lumber will be used. In general, the material will be stronger than sawn lumber scaffold planks of similar size and species. The strength is also more uniform than sawn lumber.

Like all lumber and plywood, laminated veneer lumber is subject to deterioration from weathering and rot. It must therefore be inspected periodically. Sections showing delamination, cracks, serious damage to several layers of lamination, fungi, or blisters should be discarded.

### 8.4 Sawn Lumber Planks

Rough sawn planks 48 mm x 248 mm (2 inches by 10 inches) or larger have been the standard scaffold platform material for many years. They are also the least expensive of the common platform materials. **Dressed lumber should never be used for scaffold platforms.**

The proper use of planks on a scaffold or other work platform is governed by the Construction Regulation under Ontario's *Occupational Health and Safety Act*. The regulation specifies that wooden planks used on a scaffold must

- be number 1 grade spruce
- bear a legible stamp or be permanently identified as being number 1 grade spruce
- be at least 48 mm by 248 mm ( $1\frac{7}{8}$ " x  $9\frac{3}{4}$ " )
- be arranged so their span does not exceed 2.1 metres (7 feet)
- overhang their supports by no less than 150 mm (6") and no more than 300 mm (12")
- be laid tightly side by side across the full width of the scaffold at the working level
- be cleated or otherwise secured against slipping
- be capable of carrying any load likely to be applied and as a minimum be capable of carrying 2.4 kilonewtons per square metre (50lb./sq. ft).

It is recommended that planks should meet or exceed the requirements for select structural grades of the species group used, which should be either spruce-pine-fir (SPF) or Douglas fir. Although the SPF group has less strength,

it is usually lighter and therefore easier to handle than Douglas fir. Table 8.1 provides maximum loads based on unit stresses from Canadian Standards Association Standard 086.1-1994 "Engineering Design in Wood" for Number 1 and select structural SPF plank platforms. Sawn lumber planks must be stamped by the manufacturer identifying them as scaffold planks.

Since wood planks deteriorate they must be regraded and culled periodically. For most situations, visual grading is recommended. Scaffold planks must be inspected regularly because they deteriorate with use and age, and are subject to damage. Figure 8.2 illustrates defects to look for when inspecting planks. Cull out planks with large knots in the edge, spike knots, checks, waness, worm holes, and steeply sloping grain patterns. Planks with these defects should not be used as scaffold material and should be destroyed. Scaffold planks can also be weakened by dry rot. It is not easy to notice this condition in its early stages, especially if the exterior of the planks is weathered. Planks substantially infected with dry rot are usually lighter than sound planks of similar size and species. For this reason do not use planks which feel lighter than normal.

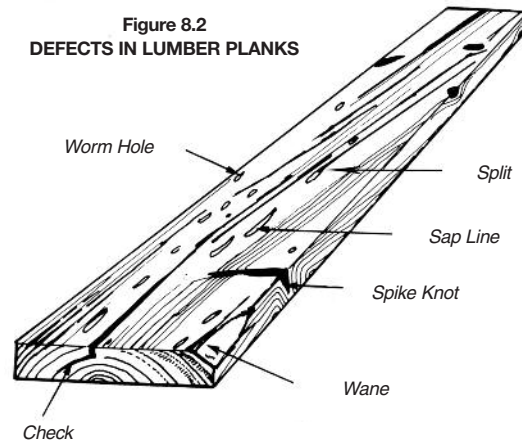

### 8.5 Reinforcing Wood Planks

Wood planks may be reinforced with metal nailer strips or plates. Research conducted by the Construction Safety Association of Ontario has indicated that the strength of weaker planks may be increased considerably by this technique but it should only be used to increase the strength of planks that are of the proper grade. Do not use this as a method of upgrading inferior grades for scaffold use.

The advantages of strengthening planks by this method are twofold:

- planks are not as likely to be cut up or used for purposes other than scaffold planks
- you have additional assurance that poorer quality planks undetected in the grading process will not break prematurely causing an accident.

**WARNING:** Nailer plates should not be placed over the portion of the plank resting on the scaffold support—unless cleats are used to prevent the plank from sliding—since there is little friction between the bearing surfaces.

Take care when handling planks reinforced in this way since sharp edges can cut your hands.

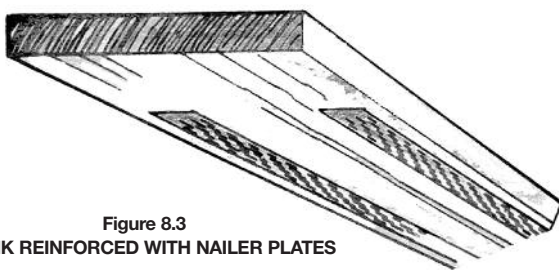

Figure 8.3  
PLANK REINFORCED WITH NAILER PLATES

### 8.6 Securing Platforms to the Frame

Be sure to secure platforms against sliding or movement. Workers frequently fall from platforms because they did not first secure the platform materials. Aluminum/plywood combination platforms have hooks that prevent longitudinal movement but will slide sideways on the scaffold unless the platform is fully decked in.

Sawn lumber planks should be cleated on at least one end to prevent longitudinal movement (Figure 8.4). You can also prevent movement by wiring a plank (Figure 8.6). Unless you carefully apply it, the wire can present a tripping hazard on the platform. Again, the platform should be fully decked in to prevent sideways movement.

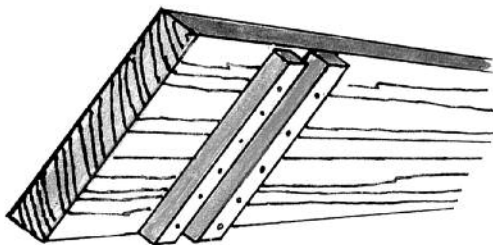
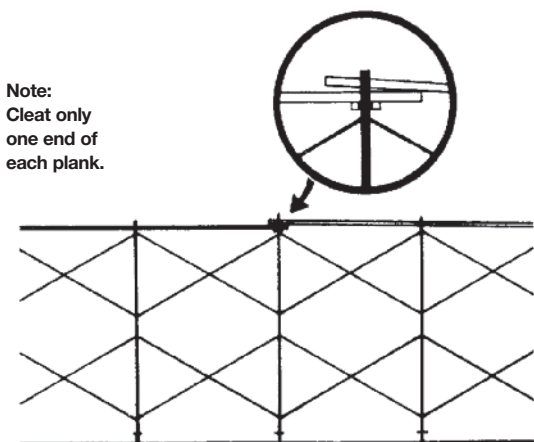

Figure 8.4  
PLANK CLEATED TO PREVENT SLIDING

If you have overlapping planks, the cleated end should be resting on the scaffold support. Be aware that the overlapped section presents a tripping hazard (Figure 8.5).

Figure 8.5  
OVERLAPPING PLANKS FOR MULTI-SPAN TOWERS



### 8.7 Wind Uplift

Wind can lift light platform materials from the scaffold if they are not secured. When you anticipate severe wind conditions or when you are using high scaffolds, you should secure platform materials such as aluminum/plywood panels to the scaffold. With some types of platform panels you can do this with wire or nails.

Others have a sliding locking device (Figure 8.1). These locking devices, however, can be easily damaged and are often difficult to apply and release.

Figure 8.6  
PLANKS WIRED TO PREVENT UPLIFT

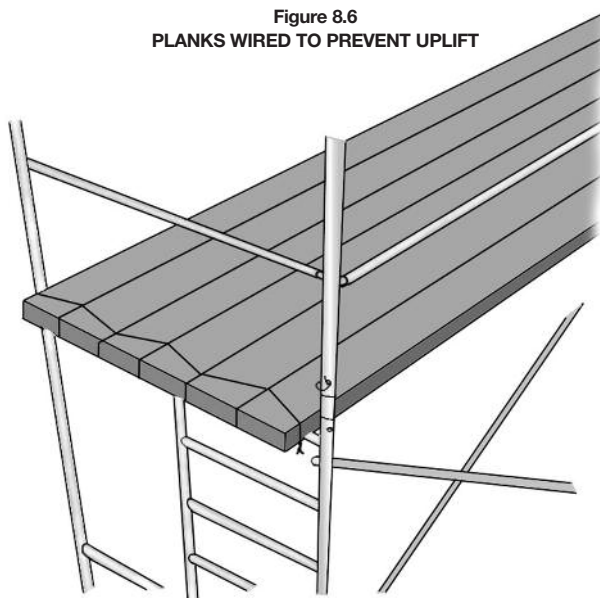

## 9 PROPER USE OF SCAFFOLDS

Much of this chapter deals with the erection and dismantling of various types of scaffolds. Frequently, the end user of the scaffold is not the person who erects it. In order for scaffolds to provide efficient access to work areas they must be used properly by all workers.

### 9.1 Ladders and Climbing

We discussed ladder access in Section 5.3. The ladder must be properly erected with rails projecting 1 metre (3 feet) above the platform of the scaffold. You should clear debris, extension cords, and tools away from areas around the top and bottom of ladders. Store materials away from these locations.

Falls often happen when workers are getting on or off the ladder at the platform level. Both hands must be free to hold guardrails or ladder rails. Do not carry tools or materials by hand when climbing ladders. Wear a tool belt and pouch and move material up or down by rope.

You should always place portable straight ladders with an adequate slope and secure them to the scaffold structure (Figure 5.5).

Always use three-point contact (Figure 9.1) when climbing ladders. This means using two hands and one foot, or two feet and one hand, to maintain contact with the ladder at all times. Always face the ladder when climbing and always keep your centre of gravity between the two ladder rails.

For more information, refer to the Ladders chapter of this manual.

### 9.2 Guardrails Missing or Removed

There may be situations where scaffolds must be used without guardrails. If the scaffold is more than one frame or tier in height and there are no guardrails, personnel on the platform must tie off with a full body harness and

Figure 9.1  
THREE-POINT CONTACT



Note: Vertical ladders above 3 metres in height must have a safety cage beginning 2.2 metres above the ground or platform. The cage is omitted here for clarity.

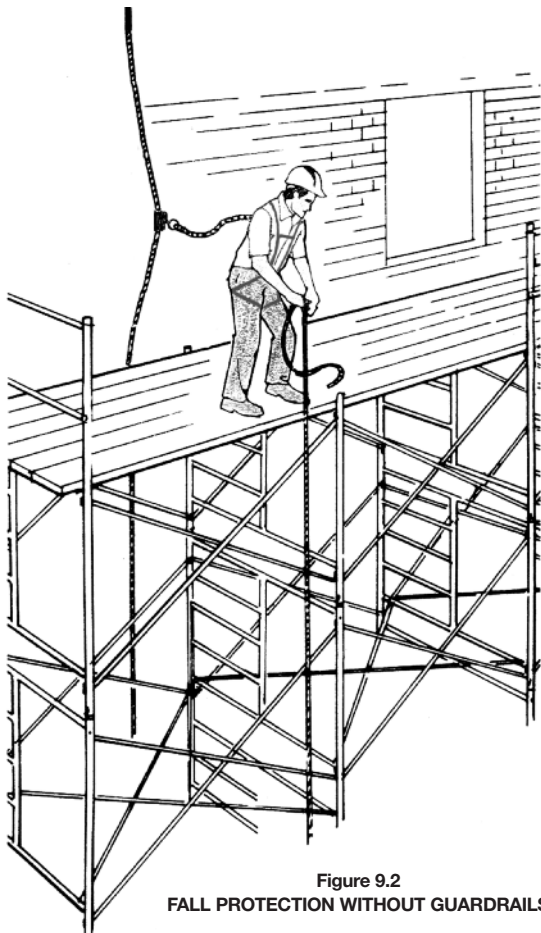

Figure 9.2  
FALL PROTECTION WITHOUT GUARDRAILS

lanyard (Figure 9.2). Many falls and serious injuries occur when workers use platforms without guardrails. Any worker who removes a guardrail for any reason must replace it when the task is completed.

### 9.3 Standing on Objects Above the Platform

People working from the platform should have both feet on the platform. Standing on a barrel, box, stepladder, guardrail, or other object to gain extra height is extremely dangerous and is illegal in most jurisdictions, including Ontario. You should know the required height of the scaffold before erecting it, so you can obtain all the required material, including half frames when necessary.

### 9.4 Overloading

Overloading scaffold platforms in the masonry trades is one of the most frequent violations of good scaffold practice. Placing full pallets of bricks or concrete blocks on a single layer of 48 mm x 254 mm (2" x 10") scaffold planks is, in most cases, overloading the platform. You may have to double plank decks to support pallets of masonry materials. Place the pallets over the supports wherever possible. In addition, inspect planks used to support masonry materials for damage or for deterioration regularly and often. Table 8.1 indicates the load-carrying capacities of various grades of plank. Table 9.1 lists the approximate weights of common building materials. Bear in mind overloading may affect stability as well as load-carrying capacity.

Differential settlement is often a problem when you apply heavy loads to scaffolds resting on uncompacted soils. A scaffold tower 9 metres (30 feet) high that settles 25 millimetres (1 inch) on one side can move 150 millimetres (6 inches) at the top. Settlement puts stress on braces, tie-ins, and frame joints. Place heavy loads symmetrically on the platform to ensure that soil settlement is uniform.

Finally, the scaffold structure must be capable of carrying the load that you will apply. Both light-duty and heavy-duty frames are available on the market. Do not use light-duty frames where you have heavy loads. If you do not know the load-carrying capacity of the frames, consult the manufacturer or supplier. The load-carrying capacity of frames usually varies with the height of the towers.

### 9.5 Debris on Scaffold Decks

Scaffold decks are small, narrow, and confined. Store tools and materials in an orderly fashion. Do not allow debris and waste materials to collect on the platform. Put them in a container or remove them from the platform immediately. Set up a plan for dealing with waste materials. Simply throwing garbage off the scaffold is extremely dangerous—don't do it. If work on the scaffold is likely to result in debris falling, such as in masonry work, then cordon off the scaffold to prevent workers from entering the area.

Waste pieces of lumber, pipe, wire, miscellaneous metal, and small tools are tripping hazards which have caused

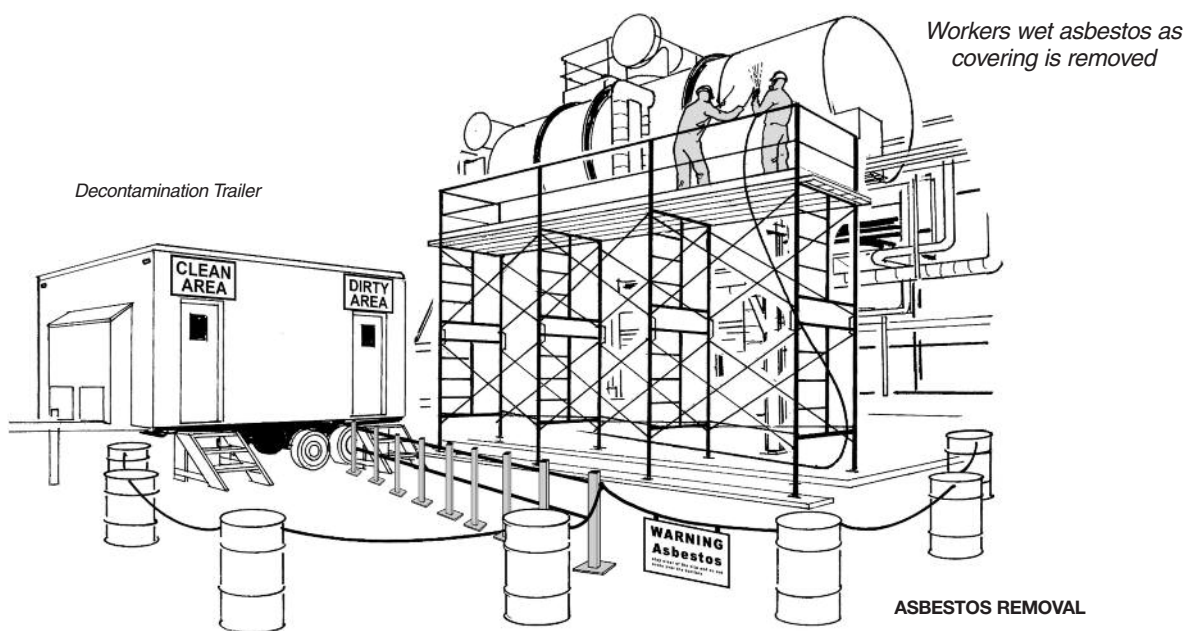

Table 9.1

APPROXIMATE WEIGHTS OF BUILDING MATERIALS

Material	Metric Unit Weight	Imperial Unit Weight
Aluminum	2643 kg/cu m	165 lb/cu ft
Iron (Wrought)	7769 kg/cu m	485 lb/cu ft
Steel	7849 kg/cu m	490 lb/cu ft
Nickel	8730 kg/cu m	545 lb/cu ft
Glass (plate)	2563 kg/cu m	160 lb/cu ft
Lumber (dry)		
Cedar (white)	352 kg/cu m	22 lb/cu ft
Douglas Fir	513 kg/cu m	32 lb/cu ft
Maple	689 kg/cu m	43 lb/cu ft
Red Oak	657 kg/cu m	41 lb/cu ft
Spruce	433 kg/cu m	27 lb/cu ft
Concrete	2403 kg/cu m	150 lb/cu ft
Granite	2803 kg/cu m	175 lb/cu ft
Brick	1922 – 2243 kg/cu m	120 – 140 lb/cu ft
Limestone, Marble	2643 kg/cu m	165 lb/cu ft
Sandstone	2082 kg/cu m	130 lb/cu ft
Steel Pipe (standard)		
1" I.D.	2.49 kg/m	1.68 lb/ft
2" I.D.	5.43 kg/m	3.65 lb/ft
3" I.D.	11.27 kg/m	7.58 lb/ft
4" I.D.	16.05 kg/m	10.79 lb/ft
Copper Pipe		
1" I.D.	2.71 kg/m	1.82 lb/ft
2" I.D.	6.28 kg/m	4.22 lb/ft
3" I.D.	13.02 kg/m	8.75 lb/ft
4" I.D.	19.20 kg/m	12.90 lb/ft
Aluminum Pipe (standard)		
1" I.D.	0.86 kg/m	0.58 lb/ft
1-1/2" I.D.	2.40 kg/m	1.61 lb/ft
2" I.D.	3.08 kg/m	2.07 lb/ft
3" I.D.	4.57 kg/m	3.07 lb/ft
Drywall (1/2" thick)	10.25 kg/m <sup>2</sup>	2.10 lb/ft <sup>2</sup>

many serious falls from scaffolds. You need an orderly work area to work safely on scaffolds.

## 9.6 Exposure to Hazardous Material

Frequently scaffolds are erected for work involving hazardous substances: e.g., refurbishing structures painted with lead-based paint. If you are sandblasting painted surfaces, lead can accumulate on planks and other components. Workers carrying out these activities must use appropriate personal protective equipment. The scaffold worker who has to dismantle the scaffold can also be at risk from the lead residue. Under these conditions you should do the following.

1. Clean components that are likely to be contaminated by lead dust, preferably by washing with a hose before dismantling begins.
2. Cap scaffolding frames and standards as the scaffold is being erected to prevent lead dust from accumulating inside and being subsequently released during the dismantling process.
3. If it is not possible to wash down the scaffolding before dismantling, then scaffold workers should wear properly fitting N100 filtering facepiece respirators while dismantling. The scaffold should then be washed before it is removed from the site.
4. Proper attention to personal hygiene is critical when dealing with lead. Workers must be instructed not to eat, drink, or smoke without washing their hands. A sign or notice indicating this should be conspicuous.
5. Workers should be provided with separate “clean” and “dirty” areas. Use the dirty area for changing out of contaminated clothing and the clean area for changing into uncontaminated clothing and eating. Washing facilities with clean water, soap, and individual towels should separate the two areas.
6. Scaffold workers should inform their physician if they are exposed to lead. The physician may want to monitor the level of lead in the person’s blood to see if it is within normal parameters.